



US007655193B1

(12) **United States Patent**  
**Rau et al.**

(10) **Patent No.:** **US 7,655,193 B1**  
(45) **Date of Patent:** **Feb. 2, 2010**

(54) **APPARATUS FOR EXTRACTING AND SEQUESTERING CARBON DIOXIDE**

(58) **Field of Classification Search** ..... 422/168, 422/169, 188; 423/220, 419.1, 420.2, 422, 423/430, 433, 437.1

(75) **Inventors:** **Gregory H. Rau**, Castro Valley, CA (US); **Kenneth G. Caldeira**, Livermore, CA (US)

See application file for complete search history.

(73) **Assignee:** **The United States of America as represented by the United States Department of Energy**, Washington, DC (US)

(56) **References Cited**

U.S. PATENT DOCUMENTS

5,261,490 A \* 11/1993 Ebinuma ..... 166/266

FOREIGN PATENT DOCUMENTS

EP 0487102 \* 5/1992

(\*) **Notice:** Subject to any disclaimer, the term of this patent is extended or adjusted under 35 U.S.C. 154(b) by 920 days.

\* cited by examiner

*Primary Examiner*—Wayne Langel

(21) **Appl. No.:** **10/901,313**

(74) *Attorney, Agent, or Firm*—Thomas S. O'Dwyer; James C. Durkis; Paul A. Gottlieb

(22) **Filed:** **Jul. 26, 2004**

(57) **ABSTRACT**

**Related U.S. Application Data**

(60) Division of application No. 09/759,781, filed on Jan. 11, 2001, now Pat. No. 6,890,497, which is a continuation-in-part of application No. 09/314,220, filed on May 19, 1999, now abandoned.

An apparatus and method associated therewith to extract and sequester carbon dioxide (CO<sub>2</sub>) from a stream or volume of gas wherein said apparatus hydrates CO<sub>2</sub> and reacts the resulting carbonic acid with carbonate. Suitable carbonates include, but are not limited to, carbonates of alkali metals and alkaline earth metals, preferably carbonates of calcium and magnesium. Waste products are metal cations and bicarbonate in solution or dehydrated metal salts, which when disposed of in a large body of water provide an effective way of sequestering CO<sub>2</sub> from a gaseous environment.

(60) Provisional application No. 60/096,846, filed on Aug. 18, 1998.

(51) **Int. Cl.**  
*B01J 8/00* (2006.01)  
*B01D 53/40* (2006.01)

(52) **U.S. Cl.** ..... 422/169

**13 Claims, 8 Drawing Sheets**

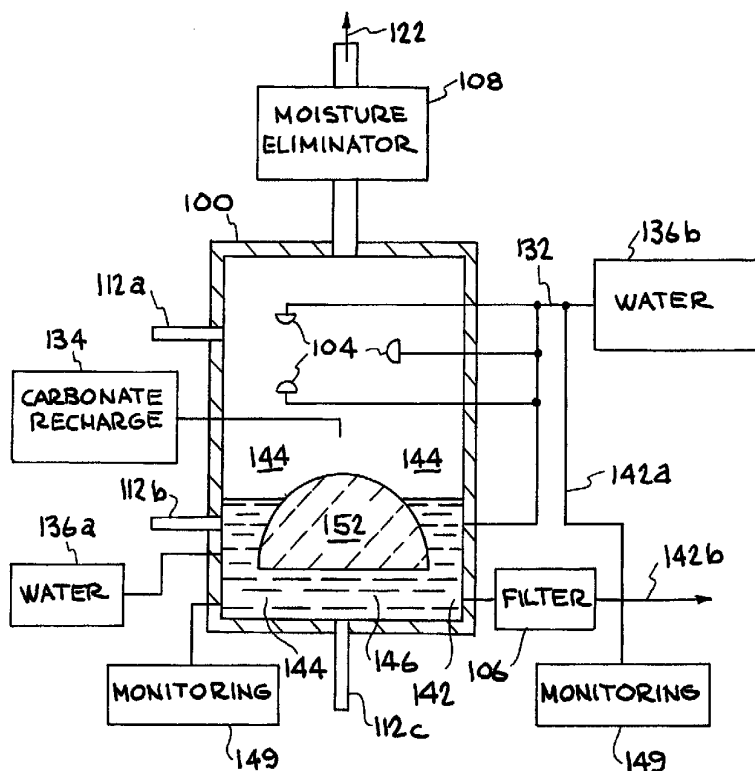



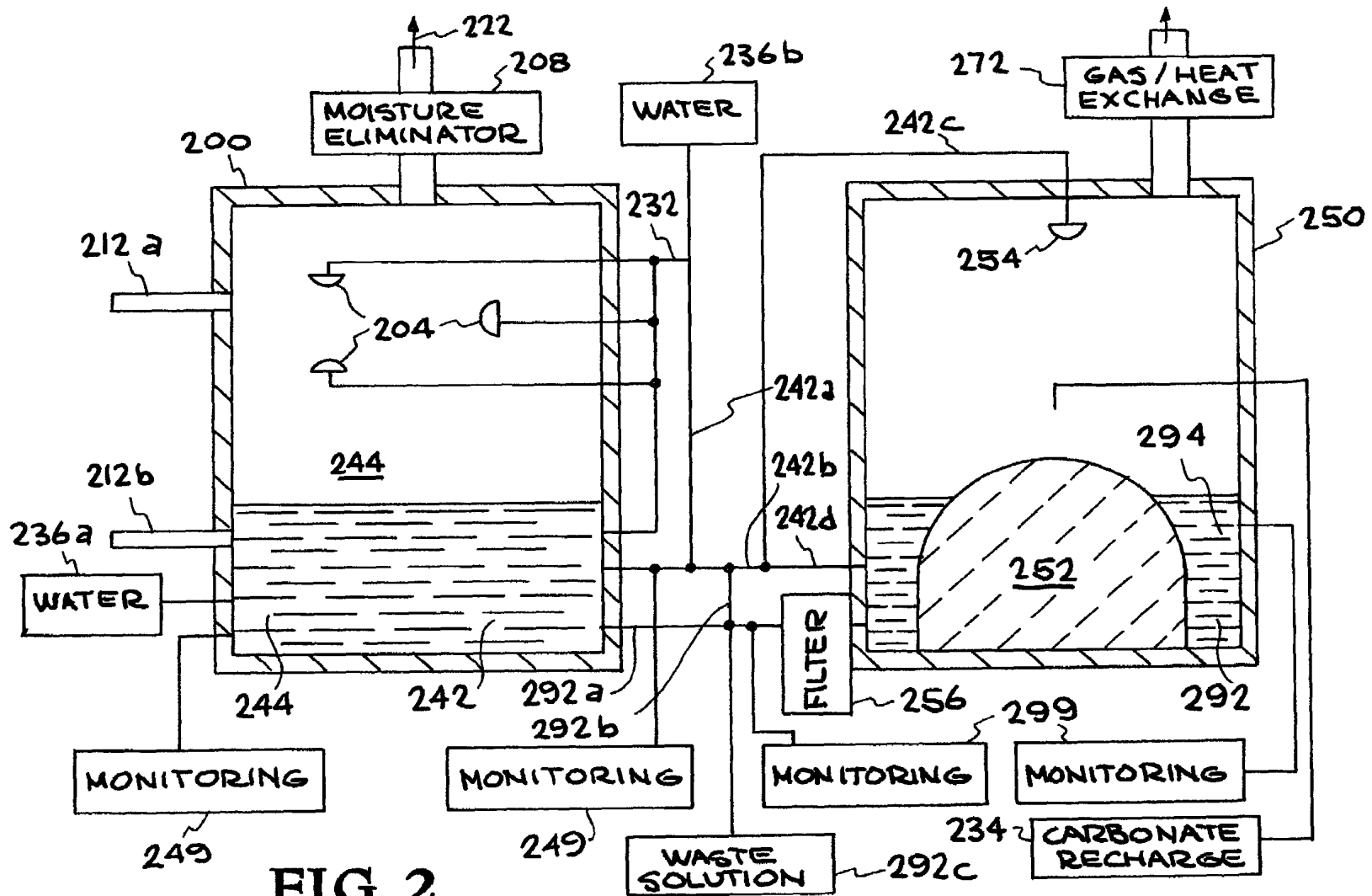

FIG. 2

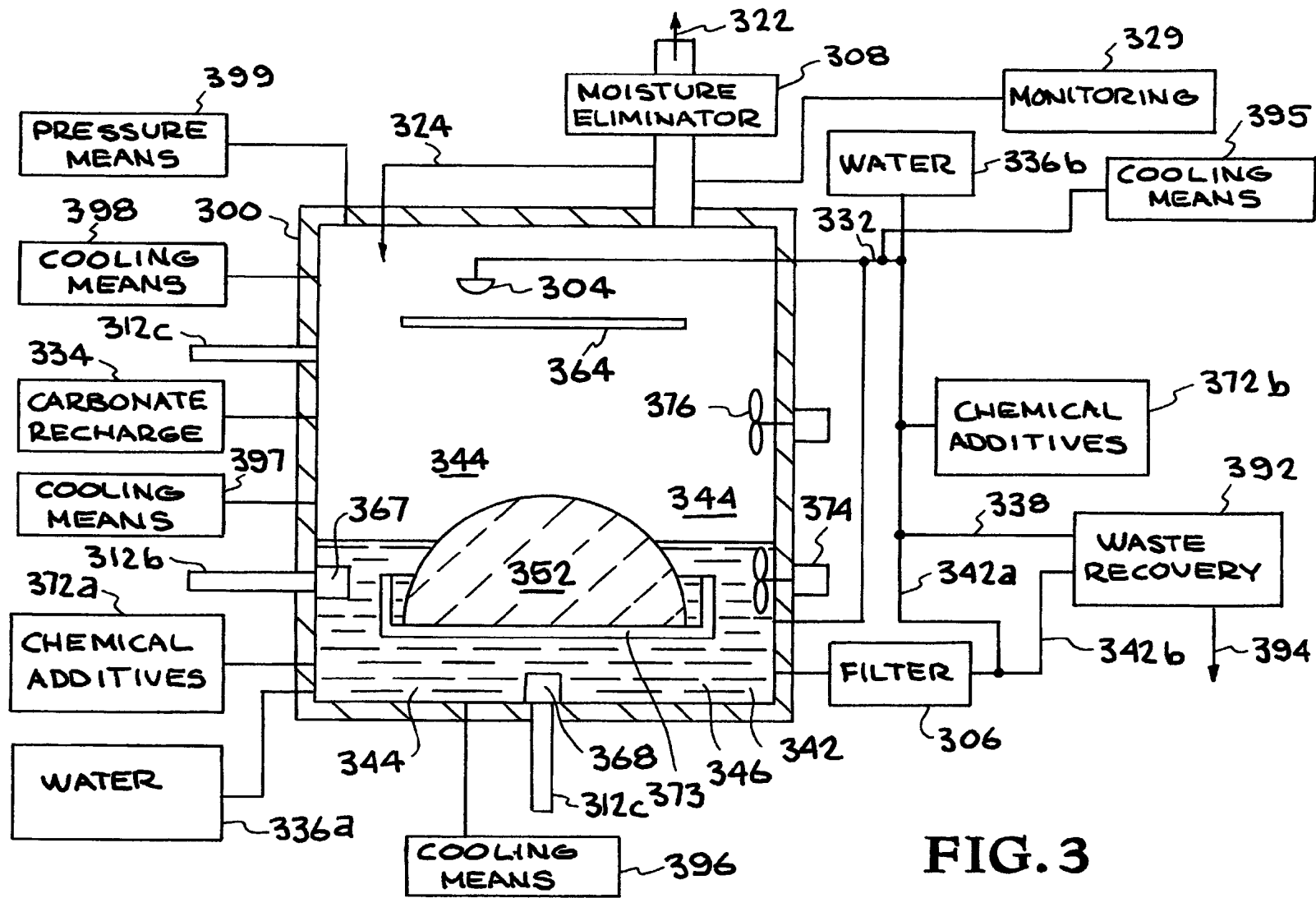
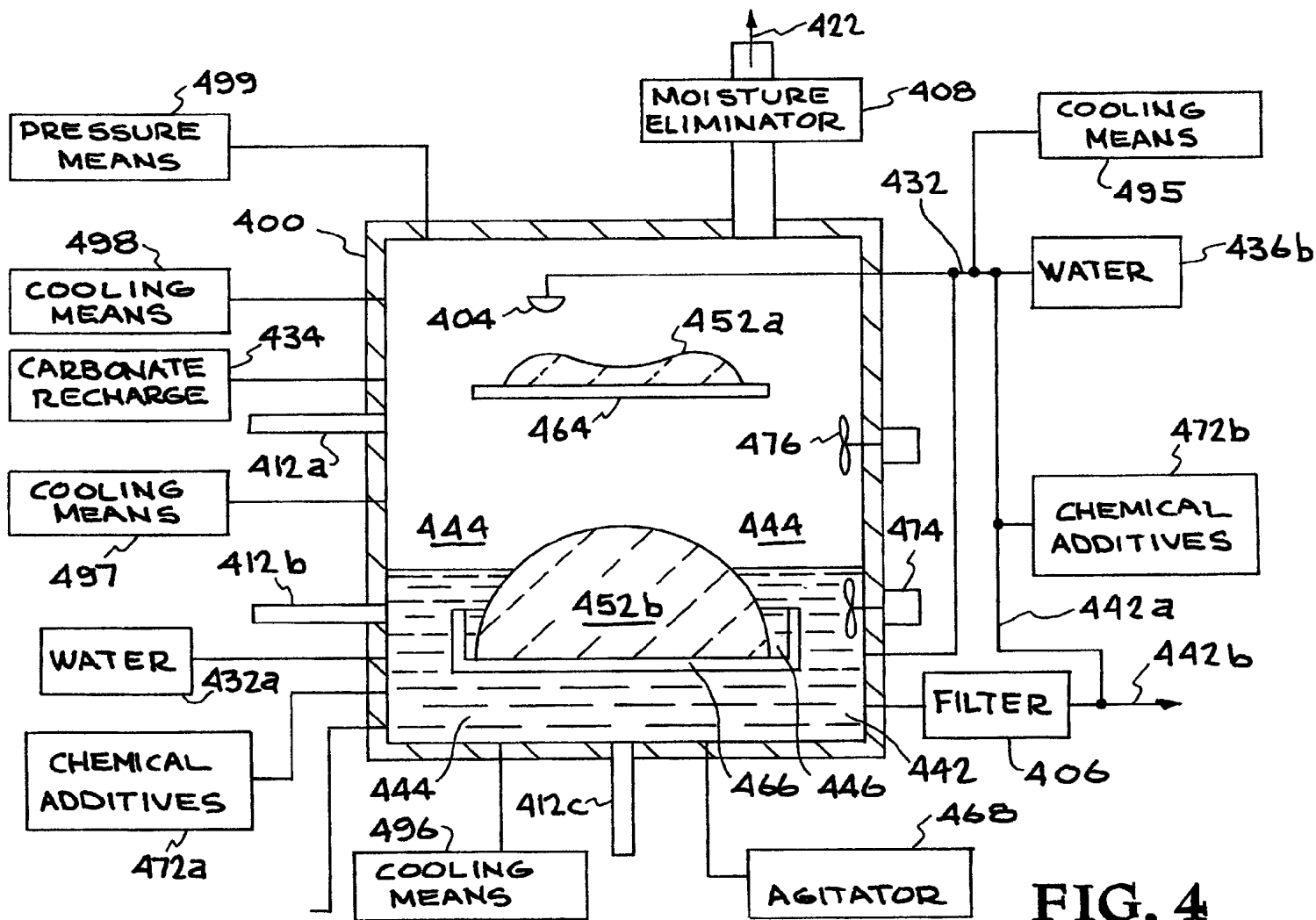
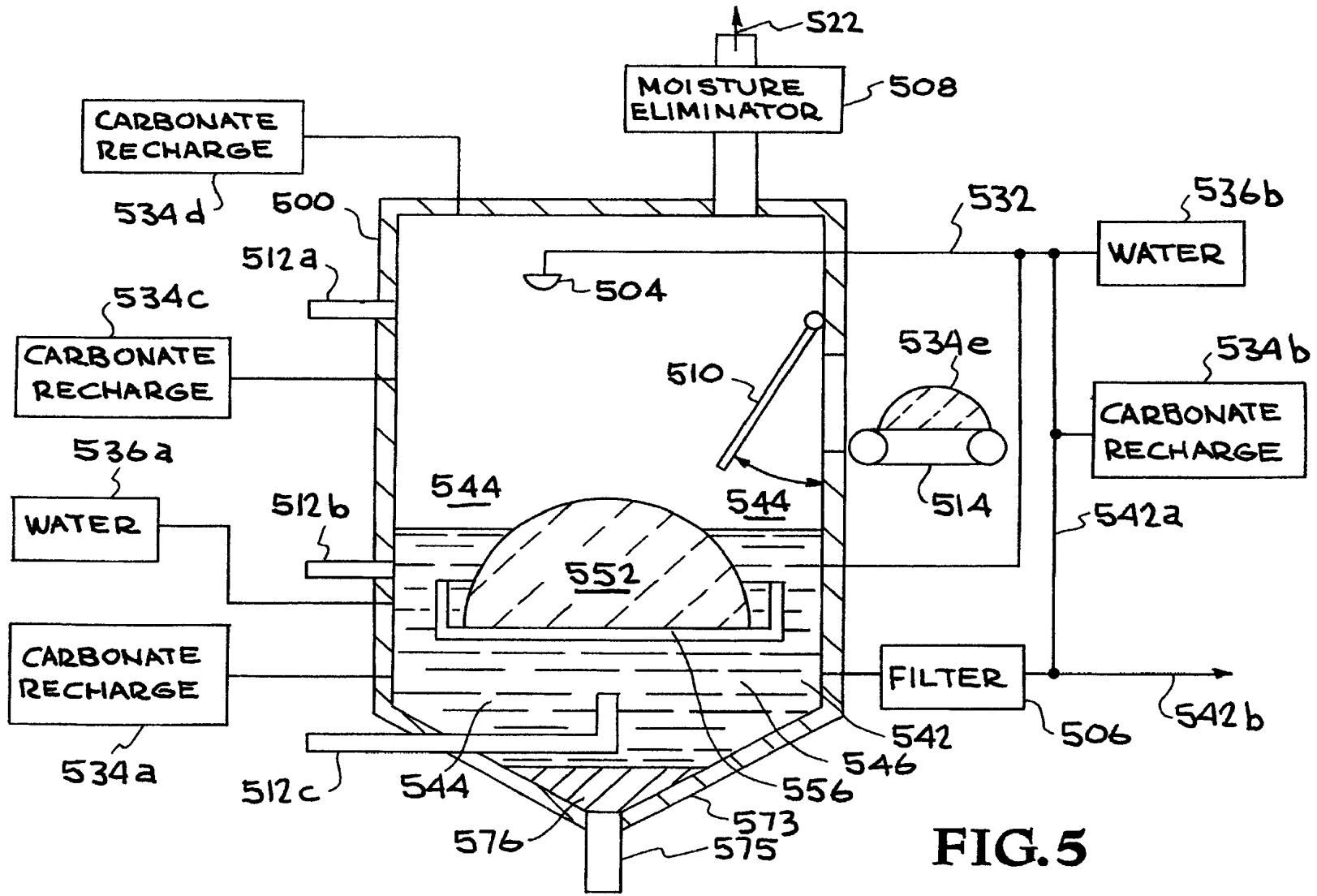

FIG. 3



**FIG. 4**



**FIG. 5**

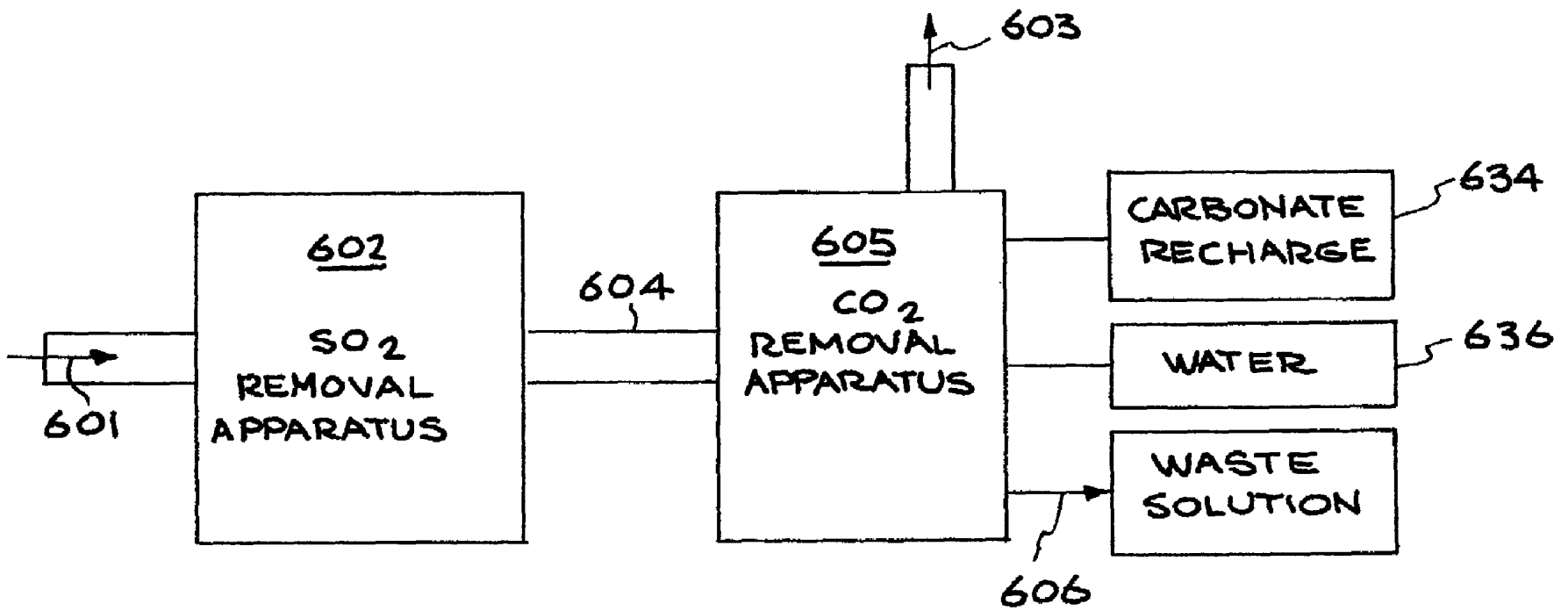

FIG. 6

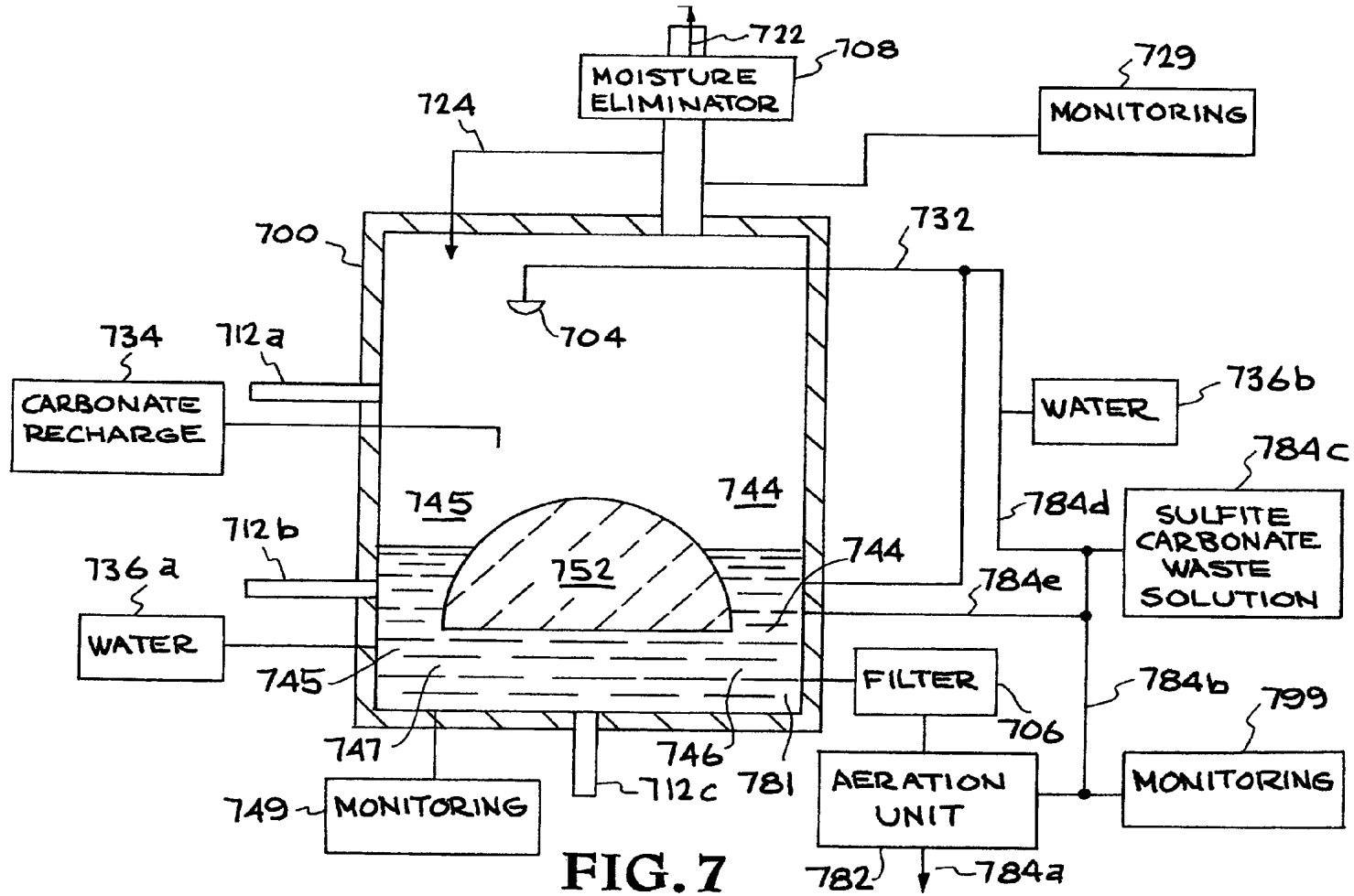

FIG. 7



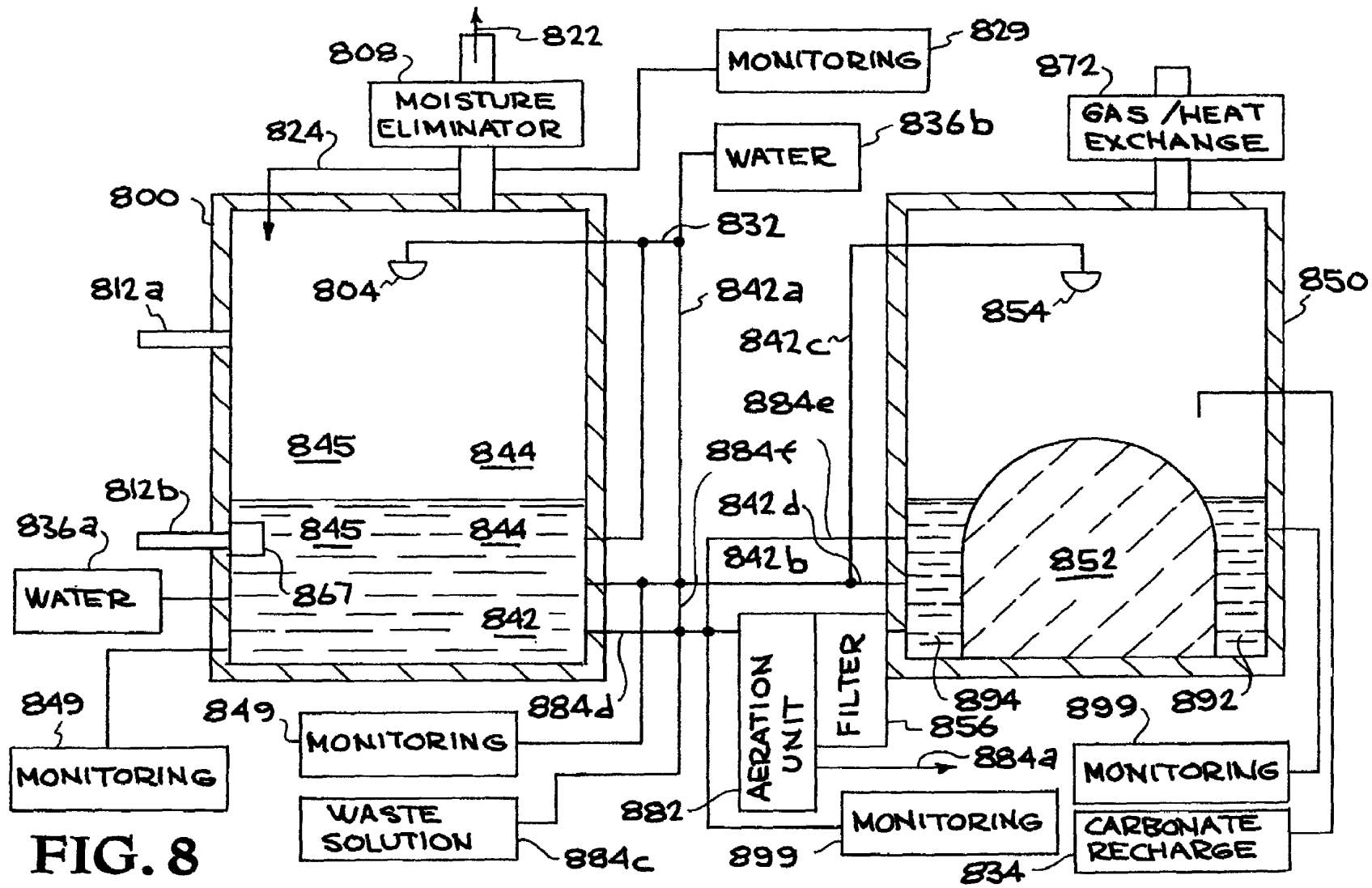

FIG. 8

**APPARATUS FOR EXTRACTING AND SEQUESTERING CARBON DIOXIDE****CROSS-REFERENCE TO RELATED APPLICATIONS**

This application is a divisional of U.S. Non-provisional application Ser. No. 09/759,781, filed Jan. 11, 2001, which is a continuation-in-part of U.S. application Ser. No. 09/314,220, filed May 19, 1999, which claims the benefit of U.S. Provisional Application No. 60/096,846, filed Aug. 18, 1998.

**STATEMENT REGARDING FEDERALLY SPONSORED RESEARCH OR DEVELOPMENT**

The United States Government has rights in this invention pursuant to Contract No. W-7405-ENG-48 between the U.S. Department of Energy and the University of California.

**REFERENCE TO A "SEQUENCE LISTING", A TABLE, OR A COMPUTER PROGRAM LISTING APPENDIX SUBMITTED ON A COMPUTER DISC (SEE 37 CFR 1.52(E)(5))**

Not Applicable

**BACKGROUND OF THE INVENTION****1. Field of the Invention**

The present invention relates generally to an apparatus and method associated therewith for extracting carbon dioxide (CO<sub>2</sub>) from a stream or volume of gas, and sequestering said CO<sub>2</sub> from the atmosphere or other gaseous environment. The invention particularly relates to an apparatus that utilizes carbonate and water to sequester said CO<sub>2</sub> as bicarbonate.

**2. Description of Related Art**

A variety of chemical means exist or have been proposed which consume CO<sub>2</sub> contained in emissions from fossil fuel combustion or other gas streams, thus reducing the potential atmospheric CO<sub>2</sub> burden (reviews by: H. Herzog and E. Drake, "Carbon Dioxide Recovery and Disposal From Large Energy Systems", Annual Reviews of Energy and Environment Vol. 21, p 145-166, 1996; X. Xiaoding and J. A. Moulijn, "Mitigation of CO<sub>2</sub> by Chemical Reactions and Promising Products", Energy and Fuels, Vol. 10, p 305-325, 1996). Among these chemical approaches, the exposure and reaction of such waste CO<sub>2</sub> to certain naturally occurring or artificially formed calcium-, magnesium-, sodium-, and/or silica-rich minerals has been explored as reviewed below. The reaction of certain carbonate and silicate minerals with CO<sub>2</sub> is a well-known "rock weathering" phenomenon that plays a major role in controlling atmospheric CO<sub>2</sub> on geologic time scales (R. A. Bemer, A. C. Lasaga, and R. M. Garrels, "The Carbonate-Silicate Geochemical Cycle and its Effect on Atmospheric Carbon Dioxide Over the Last 100 Million Years", American Journal of Science, Vol. 283, p 42-50, 1983). Over the very long term such process are expected to eventually consume most of the CO<sub>2</sub> emitted by man's activities. The problem is that such natural processes occur on the order of >1,000 year time scales and thus will have little immediate impact on the rapidly increasing CO<sub>2</sub> emissions and atmospheric CO<sub>2</sub> burden in the coming centuries. Nevertheless, several researchers have proposed that certain weathering reactions be used to sequester CO<sub>2</sub>, in particular those reactions which lead to CO<sub>2</sub> sequestration or storage in the form of solid carbonates.

For example, fixation and storage of CO<sub>2</sub> by artificial weathering of waste concrete in combination with coccolithophorid algae cultures was reported by H. Takano and T. Matsunaga, "CO<sub>2</sub> Fixation by Artificial Weathering of Waste Concrete and Coccolithophorid Algae Cultures", Energy Conversion Management, Vol. 36, No. 6-9, p 697-700, 1995. It was shown that CO<sub>2</sub> can be sequestered into biologically produced carbonate and biomass. Various mechanisms of rock weathering to fix CO<sub>2</sub> was discussed by T. Kojima, "Evaluation Strategies for Chemical and Biological Fixation/Utilization Processes of Carbon Dioxide", Energy Conversion Management, Vol. 36, No. 6-9, p 881-884, 1995. Studies of CO<sub>2</sub> fixation by silicate rock weathering were reported by T. Kojima, A. Nagamine, N. Ueno and S. Uemiya, "Absorption and Fixation of Carbon Dioxide by Rock Weathering", Energy Conversion Management, Vol. 38, Suppl., p S461-S466, 1997. Sequestering of CO<sub>2</sub> as carbonate by reaction with minerals rich in calcium and magnesium oxides was reported by K. S. Lackner, C. H. Wendt, D. P. Butt, E. L. Joyce, D. H. Sharp, "Carbon Disposal in Carbonate Minerals", Energy, Vol. 20, No. 11, p 1153-1170, 1995. Reacting flue gas CO<sub>2</sub> with water and soil to ultimately precipitate and sequester the CO<sub>2</sub> as carbonate was explored by T. Chohji, M. Tabata, and E. Hirai, "CO<sub>2</sub> Recovery From Flue Gas by an Ecotechnological (Environmentally Friendly) System", Energy, Vol. 22 No. 2/3, p 151-159, 1997. A study by H. Khesghi ("Sequestering Atmospheric Carbon Dioxide by Increasing Ocean Alkalinity", Energy, Vol. 20, No. 9, p 912-922, 1995) looked at the option of adding calcium oxide to the ocean as a means of increasing the CO<sub>2</sub> absorption capacity of the ocean. The preceding approaches often require elevated temperatures or pressures, significant energy, land, or other resource inputs, and/or have negative environmental impacts. The cost of implementing these technologies is therefore often prohibitive.

As reviewed by H. Herzog and E. Drake, (Annual Reviews, loc. cit.) several chemical means exist for separating and concentrating CO<sub>2</sub> from gas streams. U.S. Pat. No. 4,376,101 (Sartori et al) discloses the removal of CO<sub>2</sub> from a gaseous stream via use of an aqueous solution containing an alkali metal salt or hydroxide and an activator or promoter system comprising an amine compound. While such processes remove or separate CO<sub>2</sub> from a waste stream, they offer no downstream method of ultimately sequestering the CO<sub>2</sub> from the atmosphere. They also often require elevated temperatures or pressures, exotic chemicals, and/or significant inputs of energy or resources.

Gas/water/calcium carbonate (limestone) reactors have been used in desulfurization of power plants exhaust as reviewed by H. N. Soud and M. Takeshita, "FGD Handbook, IEA Coal Research, London, 438 p., 1994. Such reactors differ from the present invention in three important aspects: 1) The volume of SO<sub>2</sub> in the gas streams to which desulfurization is applied is vastly smaller than the CO<sub>2</sub> content in the same gas stream; 2) The hydration step in carbonate desulfurization involves combining SO<sub>2</sub> with H<sub>2</sub>O to form the strong acid H<sub>2</sub>SO<sub>3</sub>. In contrast, the hydration of CO<sub>2</sub> envisioned here forms carbonic acid H<sub>2</sub>CO<sub>3</sub>, a weak acid which has a slower reaction rate with carbonate than does H<sub>2</sub>SO<sub>3</sub>. 3) The reaction of H<sub>2</sub>SO<sub>3</sub> with carbonate (e.g., CaCO<sub>3</sub>) and oxygen forms a solid, CaSO<sub>4</sub>, and a gas, CO<sub>2</sub>, whereas the H<sub>2</sub>CO<sub>3</sub> with carbonate reaction forms cations and bicarbonate in solution, does not require supplemental oxygen, produces little or no solid waste, and consumes rather than generates gaseous CO<sub>2</sub>.

U.S. Pat. No. 5,100,633 (Morrison) describes a process for scrubbing acid-forming gases which include SO<sub>2</sub> and CO<sub>2</sub>

from an exhaust gas stream through reactions with alkaline solutions formed from the waste ash from biomass burning. The resulting alkali metal salts are then precipitated or dewatered forming solid, possibly useful waste products. This process does not provide a system for net CO<sub>2</sub> sequestration, however, considering that the molar ratio of carbon to alkali metals or to alkaline earth metals in the end products is many times lower than that ratio in the original biomass burned to form the alkaline ash. That is, only a very small fractional equivalent of the CO<sub>2</sub> released in biomass combustion can be sequestered by this process, and therefore when initial ash and CO<sub>2</sub> formation are considered the overall process is a net source rather than a net sink for CO<sub>2</sub>.

The chemical reactions involving CO<sub>2</sub> gas, water, and carbonate minerals (principally calcium carbonate) have been extensively studied as reviewed by J. W. Morse and F. T. Mackenzie (*"Geochemistry of Sedimentary Carbonates"*, Cambridge, Amsterdam, 707 p., 1990) and by T. Arakaki and A. Mucci (*"A Continuous and Mechanistic Representation of Calcite Reaction-Controlled Kinetics in Dilute Solutions at 25° C. and 1 Atm Total Pressure"*, *Aquatic Geochemistry*, Vol. 1, p 105-130, 1995). However, the context of these studies has been to describe the dissolution or precipitation of solid carbonate under various conditions, not the consumption and sequestration of CO<sub>2</sub>.

Due to its relative simplicity, low-cost, and low environmental impact, it is believed that the invention herein disclosed offers distinct advantages over other methods for the combined process of extracting CO<sub>2</sub> from waste gas streams and sequestering this CO<sub>2</sub> from the atmosphere.

#### BRIEF SUMMARY OF THE INVENTION

An object of this invention is a method and apparatus for extracting carbon dioxide (CO<sub>2</sub>) contained in a stream or volume of gas, and sequestering this CO<sub>2</sub> from the stream or volume of gas.

A further object is a method and apparatus which accomplishes said CO<sub>2</sub> extraction and sequestration without the requirement of elevated temperatures, pressures, and without significant expenditures of energy or other resources.

A further object is a method and apparatus which utilizes H<sub>2</sub>O and carbonate.

A further object is a method and apparatus in which the reactants are relatively abundant and inexpensive, and the end products and process waste streams are environmentally benign.

A further object is a method and apparatus whose relative simplicity and low cost allow it to be widely employed, therefore impacting CO<sub>2</sub> emissions potentially at the global scale.

A further object is a method and apparatus which can utilize a wide range of fresh- and salt-water sources.

A further object is a method and apparatus which is flexible in siting requirements allowing location near CO<sub>2</sub> sources, carbonate, and/or water sources.

It is known that carbonic acid reacts with certain metal carbonates to form metal ions and bicarbonate in solution. Such a reaction is employed in the invention to provide a means of extracting and sequestering CO<sub>2</sub> from a stream or volume of gas.

One embodiment of the present invention is an integrated apparatus comprising a reactor vessel containing carbonate. A gas stream containing CO<sub>2</sub> enters the reactor vessel. In the reactor vessel, CO<sub>2</sub> contacts an aqueous solution and becomes hydrated to form carbonic acid, which in turn reacts with the carbonate to form bicarbonate and metal ions. Waste

streams exiting the reactor vessel comprise a gas stream now depleted of CO<sub>2</sub>, and an aqueous solution of metal ions and bicarbonate.

Another embodiment of the present invention is a sequential apparatus comprising a hydration vessel and a carbonate reaction vessel. A gas stream containing CO<sub>2</sub> enters the hydration vessel. In the hydration vessel, CO<sub>2</sub> contacts an aqueous solution and becomes hydrated to form carbonic acid. The carbonic acid is transported to the carbonate reaction vessel where it reacts with carbonate located therein, to form bicarbonate and metal ions. Waste streams comprise a CO<sub>2</sub>-depleted gas stream exiting the hydration vessel and an aqueous solution of metal ions and bicarbonate exiting the carbonate reactor vessel.

The apparatus may be used in any application where the extraction and sequestration of at least part of the CO<sub>2</sub> contained in a gas stream or volume is desired. Such applications include but are not limited to CO<sub>2</sub> extraction from waste gas associated with: i) the combustion or processing of coal, petroleum, natural gas, or other fossil fuel, or organic compounds derived from the preceding, ii) the combustion, processing, or metabolism of biomass such as wood, peat, plant products, or organic compounds derived thereof, iii) the decarbonation of limestone in the production of lime, cement, and gypsum. The process may also be used to reduce the CO<sub>2</sub> burden in less concentrated sources such as bulk air.

#### BRIEF DESCRIPTION OF THE SEVERAL VIEWS OF THE DRAWING(S)

These and other features, aspects, and advantages of the present invention will become better understood with regard to the following description, appended claims, and accompanying drawings wherein:

FIG. 1 illustrates one embodiment of the present invention comprising an integrated configuration that extracts and sequesters CO<sub>2</sub> from a gas stream in which CO<sub>2</sub> is hydrated and reacted with carbonate in an integrated hydration carbonate reactor vessel;

FIG. 2 illustrates another embodiment of the present invention comprising a sequential configuration that extracts and sequesters CO<sub>2</sub> from a gas stream in which CO<sub>2</sub> is first hydrated, then the resulting carbonic acid solution is separately reacted with carbonate;

FIG. 3 illustrates further embodiments of the present invention comprising various means to enhance CO<sub>2</sub> hydration;

FIG. 4 illustrates further embodiments of the present invention comprising various means to enhance the carbonate-carbonic acid reaction;

FIG. 5 illustrates further embodiments of the present invention comprising various means to handle the carbonate;

FIG. 6 illustrates an embodiment of the present invention comprising an apparatus that receives an SO<sub>2</sub> depleted gas stream, and proceeds to sequester CO<sub>2</sub> from said gas stream by means disclosed in FIGS. 1-5. The SO<sub>2</sub> depleted gas stream is received from an apparatus that removes the SO<sub>2</sub> by conventional means well known in the art;

FIG. 7 illustrates an embodiment of the present invention comprising an integrated configuration that extracts and sequesters both SO<sub>2</sub> and CO<sub>2</sub> from a gas stream; and

FIG. 8 illustrates an embodiment of the present invention comprising a sequential configuration that extracts and sequesters both SO<sub>2</sub> and CO<sub>2</sub> from a gas stream.

#### DETAILED DESCRIPTION OF THE INVENTION

##### Definitions

alkali metals—elements found in column IA of the periodic table of elements

alkaline earth metals—elements found in column IIA of the periodic table of elements

carbon dioxide—CO<sub>2</sub>

carbonate—metal carbonate

carbonate compensation depth (CCD)—the depth in the ocean at which the rate of carbonate dissolution equals the rate of carbonate precipitation

carbonate group—CO<sub>3</sub>

carbonate ion—CO<sub>3</sub><sup>2-</sup>

carbonate solution—carbonate particles in suspension or slurry, and/or dissolved in solution

CO<sub>2</sub>-depleted gas stream—a gas stream where some or all of its initial CO<sub>2</sub> has been removed

dissolved carbonate—metal ions and carbonate ions in solution

metal carbonate—chemical compound of the form X(CO<sub>3</sub>)<sub>m</sub> where X is any element or combination of elements that can chemically bond with a carbonate group or its multiple, wherein at least one element is a group IA, IIA, IIIA, IVA, IB, IIB, IIIB, IVB, VB, VIB, VIIB, or VIIIB element of the periodic table, and m is a stoichiometrically determined positive integer. Examples of X include but are not limited to alkali metals and alkaline earth metals.

metal ion—one of the resulting cations formed when metal carbonate X(CO<sub>3</sub>)<sub>m</sub> has reacted with carbonic acid, wherein the cation is found in solution with bicarbonate, and m is a stoichiometrically determined positive integer.

pycnocline—a region of high vertical density gradients in the ocean which acts as a barrier to mixing, essentially isolating the surface mixed layer from the deeper waters and above which seawater is well-mixed and contacted with the atmosphere relative to waters below.

SO<sub>2</sub>- and CO<sub>2</sub>-depleted gas stream—a gas stream where some or all of its initial SO<sub>2</sub>- and CO<sub>2</sub> have been removed

wetted carbonate—static or moving bed, pile, or aerosol composed of carbonate particles wetted by an aqueous solution

##### Abbreviations

aq—aqueous

Ca—calcium

CO<sub>2</sub>—carbon dioxide

CO<sub>3</sub>—a carbonate group

CO<sub>3</sub><sup>2-</sup>—carbonate ion

HCO<sub>3</sub><sup>-</sup>—bicarbonate ion

H<sub>2</sub>CO<sub>3</sub>—carbonic acid

H<sub>2</sub>O—water

Mg—magnesium

Na—sodium

pCO<sub>2</sub>—the partial pressure of CO<sub>2</sub> gas

pH—the negative logarithm of the hydrogen ion concentration

SO<sub>2</sub>—sulfur dioxide

SO<sub>3</sub>—sulfite

SO<sub>4</sub><sup>2-</sup>—sulfate

X—any element or combination of elements that can chemically bond with a carbonate group or its multiple, wherein

at least one said element is a group IA, IIA, IIIA, IVA, IB, IIB, IIIB, IVB, VB, VIB, VIIB, or VIIIB element of the periodic table.

X(aq)—any element or combination of elements in solution that can chemically bond with a carbonate group or its multiple, formed when X(CO<sub>3</sub>)<sub>m</sub> dissolves in a solution.

X(CO<sub>3</sub>)<sub>m</sub>—carbonate composed of X bonded to one or more carbonate groups, where m is a stoichiometrically determined positive integer.

The inventive method and apparatus utilize a process comprising two main steps. In step 1, gaseous CO<sub>2</sub> is hydrated to form carbonic acid, as shown in equation 1:



In step 2, the hydrated CO<sub>2</sub> is reacted with a metal carbonate, in solid or dissolved form, to form metal cations and bicarbonate in solution. When the hydrated CO<sub>2</sub> or carbonic acid is reacted with a metal carbonate in solid form, this reaction may be represented as shown in equation 2a:

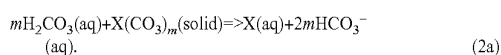

When the hydrated CO<sub>2</sub> or carbonic acid is reacted with a metal carbonate in dissolved form, this reaction may be represented as shown in equation 2b:

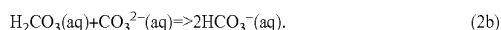

Equation 2b implies that the metal carbonate has already undergone a dissolution reaction, which may be represented by equation 3:

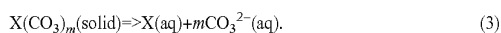

In step 2, X may represent any element or combination of elements that can chemically bond with the CO<sub>3</sub><sup>2-</sup> or its multiple, and wherein at least one element is a group IA, IIA, IIIA, IVA, IB, IIB, IIIB, IVB, VB, VIIB, VIIIB, or VIIIB element of the periodic table. Because of their natural abundance and reactivity, X would be preferably represented by a member or members of the group IA and group IIA elements. Carbonates relevant to such a reaction include but are not limited to CaCO<sub>3</sub>, CaMg(CO<sub>3</sub>)<sub>2</sub>, MgCO<sub>3</sub>, and Na<sub>2</sub>CO<sub>3</sub>. For large scale applications X represented by Ca would be preferred because of the relatively high natural abundance and low cost of CaCO<sub>3</sub> (for example, as contained in limestone). Other sources of carbonates include, but are not limited to, calcite, dolomite and aragonite. X(aq) represents one or more ions in solution containing the elements composing X.

##### CO<sub>2</sub> Hydration

In the present invention, CO<sub>2</sub> in a gas stream may be hydrated in various ways: by passing the gas stream through an aqueous solution whose surface area is enhanced, preferably by spraying or atomizing, by bubbling the gas stream into an aqueous solution, and/or by passing the gas stream over or through wetted carbonate. The gas stream may encounter the aqueous solution or wetted carbonate vertically, horizontally, or at some other angle. This gas introduction may be assisted by a compressor or other means well known in the art. This may be particularly relevant when the gas stream is bubbled into an aqueous solution, or passed through wetted carbonate that is submerged, where resistance to gas flow from the aqueous solution and/or carbonate particles is expected. Introduction of gas below wetted carbonate may serve to partially or completely fluidize the particle bed, enhancing gas-aqueous solution-carbonate contact. In this configuration the CO<sub>2</sub> hydration occurs in close proximity to the carbonate-carbonic acid reaction, and both reactions are

facilitated by the flow of gas and acid solution around the carbonate. The incoming gas is thus exposed to a large surface area of aqueous solution in the form of droplets and wetted carbonate surfaces, facilitating hydration of CO<sub>2</sub> to form a carbonic acid solution within the reactor.

#### Carbonate Forms

In the present invention, the carbonate may be presented to the carbonic acid in solid phase form, or in liquid phase form. Preferred carbonate forms include: i) pile or bed of particles (or chunks, slabs or blocks), ii) liquid slurry or suspension of particles, iii) solution of dissolved carbonate, or iv) solution or particle aerosol; over or through which the carbonic acid solution from step 1 is passed.

If the carbonate used is relatively insoluble in water, e.g., the calcium carbonate contained in limestone, then its reaction with carbonic acid in the aqueous solution will occur largely as a reaction between a liquid (carbonic acid containing solution) and a solid (limestone). Because of the abundance and relative low cost of the latter type of carbonate, the use of this carbonate type seems preferred for large scale applications.

In such applications relatively water-insoluble carbonate will be presented to the gas and aqueous solution in the reaction as a bed, pile, slurry, suspension, or aerosol of carbonate particles. The particulate carbonate may be of homogeneous or heterogeneous size and shape ranging from very fine particles to large chunks. Prior to reaction with the carbonic acid, the original size and shape of the carbonate may be modified by crushing, etching, drilling, sawing, or otherwise forming the carbonate into sizes and shapes advantageous for step 2. Because the overall rate of step 2 will be a function of the surface area of the particles exposed to the aqueous solution, the greatest surface area and hence greatest reaction rate per unit reactor volume will be achieved with the smallest sized carbonate particles. In such cases the particles in contact with the aqueous solution may form a suspension or slurry of particles depending on the size of the particles and the agitation or flow of the solution into which they are immersed. The size of such particle might be less than 0.1 mm. At the other extreme would be carbonate particle sizes, e.g., >10 cm whose individual mass would preclude prolonged suspension in air or solution and whose collective mass would then form a static bed, pile, or other configuration of carbonate particles. The aqueous solution, CO<sub>2</sub>, and carbonic acid solution would then flow in or through the porous carbonate particle mass, facilitating carbonic acid-carbonate contact and possibly gaseous CO<sub>2</sub>-aqueous solution contact. The advantage of such a scheme would be that less carbonate particle size reduction and associated cost by crushing (or other means common in the art) would be required. It would also preclude the added complexity of handling and pumping solutions containing suspended carbonate particles. With the bed/pile approach, a greater volume of particles and hence a larger reactor vessel size would be needed to attain an equivalent carbonate particle surface area within the reactor. Because it is unlikely and impractical that strict homogeneous particle sizes will be introduced into the reactor and because particle size reduction will occur in the reactor as particles of any size react with carbonic acid, it is likely that some intermediate between a static bed/pile and a dynamic suspension/slurry of carbonate will form in the reactor. The inclusion of carbonate particles in the reactor solution requires attention with regard to solution handling and pumping as will be discussed later.

If the form of the carbonate used is soluble in water, e.g. sodium carbonate, then a large portion if not all of the carbonate will be in ionic, dissolved form in aqueous solution.

This means that the carbonic acid-carbonate reaction to form bicarbonate will occur mostly if not entirely in aqueous solution. In addition to the various modes of presenting the carbonic acid to the carbonate described earlier for solid phase carbonate, liquid phase carbonate may be presented to the carbonic acid via means well known in the art, such as spraying, atomizing, blowing, and presentation on wetted structures, or as a pool of liquid into which the gas stream is bubbled.

#### Introduction, Handling, and Removal of Water and Aqueous Solution

As step 2 proceeds, the aqueous mixture in proximity to the carbonate will become increasingly saturated with bicarbonate and the rate of bicarbonate formation will subsequently decline. It may be advantageous to bleed off or remove part of the mixture and replace this removed volume with aqueous solution which is relatively unsaturated with bicarbonate. The amount and timing of such removal will be dictated by the status of the solution chemistry and the desired reaction rates. By means well known in the art, monitoring of one or more solution chemistry parameters such as pH, pCO<sub>2</sub>, conductivity, alkalinity, and/or metal ion concentration, either in the reactor solution or in the recirculating solution, is therefore desired.

Water may be added to, and solution effluent removed from, the reactor by pump, gravity feed, or other means well known in the art for liquid handling. Water addition may occur directly into the reactor or indirectly via addition to and mixture with recirculating aqueous solution prior to this mixture's introduction into the reactor. Also, carbonate solution may be added directly into the reactor or indirectly via addition to and mixture with recirculating aqueous solution prior to this mixture's introduction into the reactor.

The amount of water added to the reactor per unit time relative to the removal of waste solution effluent from the reactor will determine the solution level within the reactor. In various embodiments reactor solution may be maintained or varied at levels ranging from significantly above to significantly below the top level of the particulate carbonate bed/pile within the reactor. The liquid level will dictate the maximum height above the reactor base where solution can be withdrawn for recirculation or removal. For purposes of allowing carbonate particles to settle and for minimizing particulate load in the recirculated/removed waste solution, it would be advantageous to maintain the solution level and hence the solution outlet or outlets above the carbonate bed/pile level. On the other hand, maintaining liquid levels below the top of the carbonate bed/pile would expose the CO<sub>2</sub> gas within the reactor to a large wetted surface area formed by the exposed carbonate bed/pile as wetted by the aqueous solution spray, facilitating carbonic acid formation. In either case some carbonate particles may be entrained in the solution outflow which, if deleterious to pumps or other solution handling equipment, could be removed by filtration, settling, or other means well known in the art for liquid/solid separation.

#### Process Parameters

Certain process parameters which affect steps 1 and 2 may be varied to maximize the cost/benefit of a reactor's operation. For example, since high temperatures adversely affect the CO<sub>2</sub>-hydration and carbonate-carbonic acid reactions, low temperatures are preferred within the range between the freezing and boiling points of water for a given operating pressure. Cooling means include those well known in the art for cooling liquids and gases; such may be passive (including radiator fins or heat sinks attached to the reactor vessels or process lines), active (indirect via heat exchanger or direct

refrigeration), or a combination of the two. Such cooling means may be used to pre-cool the incoming gas stream, or to cool process particular process components including the recirculated gas stream, the gas contained in the reactor vessel, the aqueous solution, the carbonic acid, and/or such liquid as may be pooled in the reactor vessel. In addition, cooling may be achieved by having water recharge or replenishing carbonate at a lower temperature than the components in the reactor vessels. Higher total process pressures above ambient also benefit the hydration and carbonate reactions, serving to increase CO<sub>2</sub> solubility and carbonate reactivity with carbonic acid, and may be cost effective. Pressurizing means include those well known in the art such as a compressor to increase the pressure of the incoming gas stream or the gas contained within the reactor vessel. It is preferred that the highest possible concentration of carbonic acid solution be presented to the largest possible carbonate surface area, with the pH of the carbonic acid solution being as low as allowed by the operating temperature, the incoming gas stream's pCO<sub>2</sub>, the water volume with which CO<sub>2</sub> is hydrated, and the effects of chemical additives (if any). Since the solution streams in the reactor will likely range from concentrated H<sub>2</sub>CO<sub>3</sub> to concentrated HCO<sub>3</sub><sup>-</sup>, pH variation (probably 4 to 8) will need to be considered in designing the reactor bed container, and the solution and gas handling and transport systems. Other parameters to consider include: i) the CO<sub>2</sub> concentration, flow rate, and chemical composition of the gas stream entering the reactor, ii) the particle size and total amount of carbonate and thus the total carbonate surface area within the reactor, iii) the rate of physical movement or agitation (if any) of the carbonate and carbonic acid solution, iv) the reactor temperature and/or pressure, and v) the chemical properties, flow rate, and recirculation of solution within the reactor.

Various embodiments according to the present invention are described hereunder with reference to FIG. 1. In these embodiments, the H<sub>2</sub>O hydration and carbonate reactions occur together in one integrated reactor vessel 100 ("integrated configuration"). The reactor vessel 100 comprises two regions: an upper region, and a lower region. An aqueous solution 132 is introduced into the upper region of reactor vessel 100 in the form of mist or droplets via atomizer/sprayer unit 104. The atomizer/sprayer unit 104 comprises at least one atomizer/sprayer positioned wherein the mist/spray is emitted horizontally, vertically upward or downward or other angle. Aqueous solution 132 may also be introduced directly into the lower region of the reactor vessel 100 as shown. Aqueous solution 132 comprises water and may include one or more of the following: dissolved carbon dioxide, carbonic acid, metal ions, bicarbonate, particulate carbonate and dissolved carbonate. A gas stream containing CO<sub>2</sub> enters the reactor vessel 100 by one or more entry ways (112a, 112b, and/or 112c). Gas stream 112a enters the upper region of reactor vessel 100. Contact between the gas stream 112a and atomized aqueous solution 132 serves to hydrate CO<sub>2</sub>, forming carbonic acid 144. Aqueous solution 132 that is unreacted and carbonic acid 144 travel by gravity flow to the lower region of reactor vessel 100 where they impinge and wet carbonate 152 contained therein. The gas stream 112b enters the lower region of reactor vessel 100 and becomes hydrated as it bubbles through a region of unreacted aqueous solution 132 forming carbonic acid 144. Alternatively, gas stream 112b may be bubbled through unreacted aqueous solution 132 in the lower region of reactor 100 to form carbonic acid solution 144. The gas stream 112c enters the lower region of reactor vessel 100 and passes over or through wetted carbonate 152 wherein the CO<sub>2</sub> hydration and carbonate-carbonic

acid reactions occur in close proximity. The gas stream 112c may be configured to pass over or through carbonate 152 in the vertical, horizontal, or other direction as may be desired. The CO<sub>2</sub>-depleted gas stream 122 exits the reactor vessel 100. Prior to exiting from the reactor vessel 100, the gas stream 122 may be passed through a moisture-eliminator 108. The carbonic acid 144 reacts with carbonate 152 to form metal ion/bicarbonate solution 146. Mixture 142 comprises metal ion/bicarbonate solution 146, unreacted aqueous solution 132, and unreacted carbonic acid 144 which have pooled in the lower region of reactor vessel 100. Mixture 142 is bled from the reactor and disposed of as waste solution 142b and/or recirculated 142a. Water 136b may be added to mixture 142a as it is circulated back to atomizer/sprayer unit 104, or water 136a may be added directly to the lower region of the reactor vessel 100. Carbonate recharge means 134 is provided for adding carbonate to reactor vessel 100. To prevent entrainment of large particulate carbonate, mixture 142 may be passed through a solid/liquid separation means, such as a filter, 106. Portions of the carbonate 152 may extend above the liquid level of mixture 142, thereby exposing the carbonate 152 directly to the atomized aqueous solution 132 and carbonic acid 144. Monitoring means 149 is provided for measuring one or more solution chemistry parameters such as pH, pCO<sub>2</sub>, conductivity, alkalinity, and/or metal ion concentration, in mixture 142 either within the reactor vessel 100 or as the mixture is transported outside of the reactor vessel 100.

Further embodiments according to the present invention are described hereunder with reference to FIG. 2. In these embodiments, ("sequential configuration"), CO<sub>2</sub> hydration occurs in a hydration-vessel and the carbonate-carbonic acid reaction occurs in a carbonate reaction vessel, with the hydration vessel being located upstream from the carbonate reaction vessel. Unless otherwise stated, similarly numbered components are analogous to components in the previous figure. The hydration vessel 200 comprises two regions: an upper region, and a lower region. An aqueous solution 232 is introduced into the upper region of hydration vessel 200 in the form of mist or droplets via atomizer/sprayer unit 204. The atomizer/sprayer unit 204 comprises at least one atomizer/sprayer positioned wherein the mist/spray is emitted horizontally, vertically upward or downward or other angle. Aqueous solution 232 may also be introduced directly into the lower region of hydration vessel 200. Aqueous solution 232 comprises water and may include one or more of the following: dissolved carbon dioxide, carbonic acid, metal ions, bicarbonate, particulate carbonate and dissolved carbonate. A gas stream containing CO<sub>2</sub> enters hydration vessel 200 via one or more pathways 212a,b. Gas stream 212a enters the upper region of hydration vessel 200. Contact between the gas stream 212a and aqueous solution 232 serves to hydrate CO<sub>2</sub> forming carbonic acid 244. The gas stream 212b enters the lower region of hydration vessel 200 and becomes hydrated as it bubbles through a region of unreacted aqueous solution 232 and carbonic acid 244. The CO<sub>2</sub>-depleted gas stream 222 exits hydration vessel 200 as shown. Prior to exiting from the hydration vessel 200, the depleted gas stream 222 may be passed through a moisture eliminator 208. Mixture 242 comprises carbonic acid 244, aqueous solution 232, and may contain mixture 292. Mixture 242 is transported to carbonate reaction vessel 250 as shown in 242b, or recirculated 242a. Water 236b may be added to mixture 242a as it is recirculated back to atomizer/sprayer unit 204, or water 236a may be added directly to the lower region of the hydration vessel 200. Carbonate reaction vessel 250 comprises upper and lower regions. Mixture 242b may be introduced into the upper region of carbonate reaction vessel 250 in the form of mist or

droplets **242c** via atomizer/sprayer unit **254**, and/or directly **242d** into the lower region of carbonate reaction vessel **250**. Mixture **242c** and/or **242d** react with carbonate **252** contained in the lower region of carbonate reactor **250** to form metal ions/bicarbonate solution **294**. Mixture **292** comprises metal ion/bicarbonate solution **294** and unreacted mixtures **242c** and/or **242d** which have pooled in the lower region of carbonate reaction vessel **250**. Mixture **292** is bled from the carbonate reaction vessel **250** and disposed of as waste solution **292c**, recirculated **292a** back to hydration vessel **200** for facilitating further CO<sub>2</sub> hydration, and/or recirculated **292b** for mixing with mixture **242b**. Carbonate recharge means **234** is provided for adding carbonate to the carbonate reactor **250**. To prevent entrainment of large particulate carbonate, mixture **292** may be passed through a solid/liquid separation means, such as a filter, **256**. Portions of the carbonate **252** may or may not extend above the liquid level of mixture **292**, thereby exposing the carbonate **252** directly to the atomized mixture **242c**. Carbonate reaction vessel **250** may also contain gas/heat exchange means **272** whereby gas is vented and heat may be exchanged with the ambient atmosphere to moderate interior gas pressure and temperature. Monitoring means **249** and **299** are provided for measuring one or more solution chemistry parameters such as pH, pCO<sub>2</sub>, conductivity, alkalinity, and/or metal ion concentration, in mixtures **242** and **292** either within reactors **200** and **250**, or in the effluent solution.

#### Hydration Enhancement

The object for step 1 is to efficiently obtain the highest possible carbonic acid concentration for the step 2 reaction. The efficiency of CO<sub>2</sub> hydration can be enhanced by:

- i) increasing the surface area of an aqueous solution in contact with a given volume of CO<sub>2</sub>. Generally, for a given aqueous solution and CO<sub>2</sub> volume this can be accomplished by minimizing the size of the aqueous solution droplets, by maximizing the wetted surface area exposed to the CO<sub>2</sub>, and/or agitating, mixing, flowing, or stirring the CO<sub>2</sub> and aqueous solution.
- ii) increasing the concentration of pCO<sub>2</sub> in the incoming gas stream, achieved by pre-concentrating the CO<sub>2</sub> in the gas stream, using means well known in the art, before the gas stream enters the reactor and/or increasing the total gas pressure within the reactor.
- iii) increasing CO<sub>2</sub> solubility by decreasing temperature.
- iv) adding chemical compounds which catalyze or enhance step 1 (e.g., carbonic anhydrase).

One means of maximizing the wetted surface area of an aqueous solution exposed to the CO<sub>2</sub> is achieved by use of high surface-area-to-volume-ratio structure(s). Such structures include porous materials, grates, grills, wires, mesh, screens, beads, balls, plates, fins, vanes, conveyor belts and other structures well known in the art of gas-liquid contacting (J. R. Fair, D. E. Steinmeyer, W. R. Penney and B. B. Crocker. "Gas Absorption and Gas-Liquid System Design, In: R. H. Perry, D. W. Green, and J. O. Maloney (eds.) Perry's Chemical Engineers' Handbook, 7th Ed., McGraw-Hill, New York, pg. 14-1 to 14-98, 1997 which is incorporated herein by reference). These structures may be stationary or in motion (linear, rotational, unidirectional and/or reciprocating), moved, shaken, vibrated, or otherwise agitated to further facilitate gas-solution contacting.

Various means are well known in the art for agitating the CO<sub>2</sub> and aqueous solution to increase contact. Such means may include mixers, mechanical or electromagnetic stirrers, blowers, spinners, shakers, vibrators or other agitating means well known in the art.

The carbonic acid solution may be recirculated for further CO<sub>2</sub> hydration with CO<sub>2</sub> to approach CO<sub>2</sub> saturation and hence the maximum carbonic acid concentration. The aqueous solution used in the CO<sub>2</sub> hydration step need not be pure H<sub>2</sub>O, due either to recirculation of reacted water or the presence of other ions or chemicals in the water prior to use in step 1. Increasing the solution's ionic strength may adversely affect CO<sub>2</sub> solubility to a small extent. Sources of water, which may be used in step 1 which would contain a significant burden of ions and chemicals prior to reaction, include but are not limited to industrial waste water and seawater.

The solution effluent removed from the reactor will contain significantly elevated bicarbonate, carbonate, and CO<sub>2</sub> concentrations. If exposed to ambient air or other low-CO<sub>2</sub> gas, the differential in CO<sub>2</sub> concentration between air and the solution will cause CO<sub>2</sub> to degas from solution, increasing saturation state of the carbonate in solution, which could lead to the precipitation of solid carbonate from the solution. If such precipitation is undesired, it may be reduced or eliminated by copious dilution of effluent solution with water or other solution which is undersaturated with respect to carbonate. Carbonate precipitation may also be hindered by the addition to the effluent of certain ions such as SO<sub>4</sub><sup>2-</sup> and PO<sub>4</sub><sup>2-</sup> (Morse and Mackenzie, op cit.). Conversely, it may be advantageous to concentrate or solidify part or all of the bicarbonate/carbonate ion load in the effluent through effluent dewatering by means well known in the art, including drying, distillation, evaporation and membrane separation, described in Mark's Standard Handbook for Mechanical Engineers, eighth edition, pages 6-192 to 6-195, which is incorporated herein by reference. The resulting concentrated bicarbonate/carbonate slurry or solid could then be discarded, or used as chemical feedstock or other useful purpose. Since CO<sub>2</sub> dissolved in the effluent may come out of solution during the dewatering process, it may be advantageous to capture this CO<sub>2</sub>. Further embodiments would include a means to capture and recirculate the water removed in the dewatering process for reuse in the CO<sub>2</sub> hydration step or for other uses, and/or a means of recirculating the captured CO<sub>2</sub> back to the reactor for hydration to form carbonic acid.

Further embodiments of the present invention comprising means to enhance CO<sub>2</sub> hydration are shown in FIG. 3. Although the embodiments are depicted for the integrated configuration, these hydration means are equally applicable to the sequential configuration as well. Unless otherwise stated, similarly numbered components are analogous to components in the previous figures. As stated earlier, CO<sub>2</sub> hydration may benefit from use of high surface-area-to-volume-ratio structures. Screen **364**, in the reactor vessel **300** upper region, partially intercepts and is contacted by the aqueous solution **332** and gas stream **312a** thereby enhancing formation of carbonic acid solution **344**. The CO<sub>2</sub>-depleted gas stream **322** may be recirculated **324** back into reactor vessel **300** should further CO<sub>2</sub> removal be necessary. Monitoring means **329** is provided for monitoring the CO<sub>2</sub> concentration in gas stream **322**. Prior to exiting from the reactor vessel **300**, the gas stream **322** may be passed through a moisture-eliminator **308**. Carbonic acid **344** reacts with carbonate **352** to form metal ion/bicarbonate solution **346**. Mixture **342** comprises unreacted carbonic acid **344**, aqueous solution **332** and metal ion/bicarbonate solution **346** which have pooled in the lower region of reactor vessel **300**. Agitating means **374** may be located in the reactor vessel **300** lower region to enhance contact between the gas streams **312b**, **312c**, carbonate **352** and mixture **342**. Agitating means **376** may be located in the reactor vessel **300** upper region to enhance contact between the gas stream **312a** and aqueous

solution 332. Gas streams 312*b* and 312*c* may be passed through gas diffusers 367 and 368 respectively to enhance dispersal of the gas into the collected liquid in the lower region of reactor vessel 300. Chemical additives, such as the CO<sub>2</sub>-hydration-catalyst carbonic anhydrase, may be added to the reactor to enhance carbonic acid formation, 372*b* shown as being added to aqueous solution 332 and 372*a* shown as being added directly to reactor vessel 300. The carbonate 352 may be held in a liquid-porous/gas permeable container 373. The container 373 may be in motion (linear, rotational, unidirectional and/or reciprocating) which serves to enhance contact between the carbonate 352, aqueous solution 332, carbonic acid 344 and gas entering via pathways 312*b* or 312*c*. To prevent entrainment of large particulate carbonate, mixture 342 may be passed through a solid/liquid separation means, such as a filter, 306. Water 336*b* may be added to mixture 342*a* as it is recirculated back to atomizer/sprayer unit 304, or water 336*a* may be added directly to the lower region of the reactor vessel 300. Carbonate recharge means 334 is provided for adding carbonate to reactor vessel 300. Waste solution 342*b* may be passed to water recovery unit 392 which concentrates the metal ions/bicarbonates and extracts the water by means well known in the art. Reclaimed water 338 and/or CO<sub>2</sub> derived from unit 392 may be added 338 to mixture 342*a* as shown and recirculated to reactor 300. Concentrated metal ion/bicarbonate 394 exits component 392 as shown. Aqueous solution 332 may be passed through cooling means 395 to enhance CO<sub>2</sub> solubility. Mixture 342 may be passed through cooling means 396 to enhance CO<sub>2</sub> solubility. Cooling means 397 serves to cool the gas present in the upper region of reactor vessel 300 to enhance CO<sub>2</sub> solubility. Passive cooling means 398 serves to remove heat from the interior of reactor vessel 300 to enhance CO<sub>2</sub> solubility. Pressure means 399 serves to increase the total pressure in reactor vessel 300 to enhance CO<sub>2</sub> solubility.

#### Carbonic Acid/Carbonate Reaction Enhancement

Various means may be used to enhance the reaction of the carbonate with the carbonic acid. Although the carbonate-carbonic acid reaction is not restricted to the use of specific carbonate material sizes (allowable sizes may range from particles of less than 1 micron to greater than 1 meter, e.g., chunks, slabs or blocks), maximizing the surface area of the carbonate presented per volume of carbonic acid solution will maximize the overall rate of the reaction. For a given reactor volume, carbonate surface area is maximized by minimizing the size of the individual carbonate particles used in the reactor. Use of high surface-area-to-volume-ratio structures to hold, support or contact the carbonate could serve to increase the surface area of carbonate presented per volume of carbonic acid. Such structures include but are not limited to porous materials, grates, grills, plates, wires, mesh, screens, beads, balls, fins, vanes, liquid-porous containers, conveyor belts and other structures well known in the art. Such structures may be stationary or in motion (linear, rotational, unidirectional and/or reciprocating), moved, shaken, vibrated or otherwise agitated to facilitate carbonate/carbonic acid contact.

Although the carbonic acid solution is shown in the Figures as flowing vertically downward over/through the carbonate, the flow configuration is not limited to such. Flow may be vertically upward, horizontal, or at an angle as well. If the carbonate is a slurry, in suspension, dissolved in solution or in aerosol form, other ways of mixing the carbonate and carbonic acid solution may be used as well, including mixing the two components while airborne. The carbonate itself may be static or in motion, as may the structure(s) supporting or

containing the carbonate. Having the carbonate in motion (such as a flowing slurry), or moving structure (such as a conveyor belt) may facilitate replenishment of the carbonate for a continuous operation. The direction of movement may be counter, tangential, parallel, or circular to the gas or solution flows or various combinations or these movements according to the desired efficiency of contacting the reactants.

For purposes of enhancing carbonic acid and carbonate contact it may be advantageous to agitate part or all of the reactor or its contents so as to reduce the boundary layer thickness between the unreacted carbonate and carbonic acid solution. Such agitation could be imparted externally to the reactor or to some or all of its contents by one or more shakers, mechanical or electromagnetic stirrers, mixers, spinners, blowers, vibrators, or other agitation means well-known in the art. The carbonate-carbonic acid reaction may also be enhanced by recirculation of unreacted carbonic acid solution within or through the reactor.

Enhanced carbonate-carbonic acid reaction may be achieved by lowering of the reaction temperature. Since the CO<sub>2</sub>-hydration and carbonate-carbonic acid reactions are mildly exothermic, it may be advantageous to modulate reactor heat loss and hence reactor temperature, as well as varying aqueous solution, carbonic acid or gas flow rates or temperatures so as to maximize reaction rates while also preventing excessive H<sub>2</sub>O vaporization.

Step 2 (carbonate-carbonic acid reaction) is also enhanced by: i) decreasing the pH of the reacting solution, ii) increasing the ionic strength of the reacting solution, and iii) removing or chemically binding chemical impurities (e.g., certain metals, phosphate, sulfite, sulfate, fluoride and organic compounds) which may impede step 2. With regard to iii), if such contaminants deleterious to step 2 are present in the incoming gas or water streams, it would be advantageous to reduce, separate, or remove such contaminants from these streams prior to steps 1 or 2. One way of achieving this would to include chemical additives such as metal or ion chelators or chemical inhibitors of such contaminants (e.g., ethylene-diamine tetraacetate, EDTA) in aqueous solutions within the reactor.

Further embodiments of the present invention comprising various means to enhance the carbonate-carbonic acid reaction are shown in FIG. 4. Although the embodiments are depicted for the integrated configuration, these structures are equally applicable to the sequential configuration as well. Unless otherwise stated, similarly numbered components are analogous to components in the previous figures. In one embodiment, screen 464 is located in the upper region of reactor vessel 400 upon which carbonate 452*a* is disposed. Aqueous solution 432, emitted from atomizer/sprayer unit 404, impinges and wets screen 464 and carbonate 452*a*. Gas stream 412*a* passes over or through screen 464. Carbonic acid 444 is formed as CO<sub>2</sub> from the gas stream becomes hydrated by aqueous solution 432. As the gas stream 412*a* passes over wetted carbonate 452*a*, further carbonic acid 444 is formed and a carbonate-carbonic acid reaction occurs. Prior to exiting from the reactor vessel 400, CO<sub>2</sub>-depleted gas stream 422 may be passed through a moisture-eliminator 408. Agitating means 476 may be located in the upper region of reactor vessel 400 to enhance contact between the gas stream 412*a* and aqueous solution 432. Mixture 442 comprises unreacted carbonic acid 444, aqueous solution 432 and metal ion/bicarbonate solution 446 which have pooled in the lower region of reactor vessel 400. Agitating means 474 may be located in the reactor vessel 400 lower region to enhance contact between the gas streams 412*b* and 412*c*, carbonate 452*b*, and mixture 442. Chemical additives, such as metal or ion chelators or chemical inhibitors, may be added to reduce contaminants



that would interfere with the carbonic acid/carbonate reaction, **472b** shown as being added to aqueous solution **432**, and **472a** shown as being added directly to the lower region of reactor vessel **400**. Mixture **442** is bled from the reactor and disposed of as waste solution **442b** and/or recirculated **442a**. To prevent entrainment of large particulate carbonate, mixture **442** may be passed through a solid/liquid separation means, such as a filter, **406**. Water **436b** may be added to mixture **442a** as it is recirculated back to atomizer/sprayer unit **404**, or water **436a** may be added directly to the lower region of the reactor vessel **400**. Carbonate recharge means **434** is provided for adding carbonate to reactor **400**. Carbonate **452b** may be contained in a liquid-porous container **466** permeable to carbonic acid that is submerged in carbonic acid **444**. Container **466** may be stationary or in motion relative to said carbonic acid **444**. Reactor vessel **400** may further contain agitating means **468** which vibrates or shakes the lower region of reactor vessel **400**. Aqueous solution **432** may be passed through cooling means **495** to enhance carbonate reactivity. Mixture **442** may be passed through cooling means **496** to enhance carbonate reactivity. Cooling means **497** serves to cool the gas present in the upper region of reactor vessel **400** to enhance carbonate reactivity. Passive cooling means **498** serves to remove heat from the interior of reactor vessel **400** to enhance carbonate reactivity. Pressure means **499** serves to increase the total pressure in reactor vessel **400** to enhance carbonate reactivity.

#### Carbonate Handling

The carbonate is introduced/replenished in the reactor either as dry particles, as wetted or immersed particles, or dissolved in ionic form in water or other appropriate aqueous solution using methods well known in the art of solids or solution transport including but not restricted to conveyor belts, pumps, blowers, and sprayers (e.g., D. A. Dahlstrom and others, "Liquid-Solid Operations and Equipment", In: R. H. Perry, D. W. Green, and J. O. Maloney (eds.) Perry's Chemical Engineers' Handbook, 7th Ed., McGraw-Hill, New York, pg. 18-1 to 18-133, 1997.). The introduction of the carbonate may occur vertically, horizontally, or at some other angle relative to the reactor bed. Carbonate may be added to the reactor by various means, including a passive gravity feed or stream, or by active pumping, spraying, blowing, or conveying of dry, wet, or immersed carbonate particles or carbonate solution into the headspace or into the lower region of the reactor, in batch mode or continuous feed mode. In other embodiments, particulate carbonate within the reactor may be held by or fastened onto structures such as static or moving porous materials, grates, grills, plates, screens, wires, mesh, beads, balls, fins, vanes, conveyor belts, or held in liquid-porous containers, whose purpose is to facilitate carbonate addition to the reactor. As was stated earlier, lower temperatures facilitate the carbonate-carbonic acid reaction. Therefore it may be advantageous to replenish the carbonate with carbonate at a lower temperature than that in the carbonate reaction vessel.

Further embodiments of the present invention comprising carbonate handling means, including means to add carbonate to the reactor vessel are shown in FIG. 5. Although the embodiments are depicted for the integrated configuration, these carbonate replenishment means are equally applicable to the sequential configuration as well. Unless otherwise stated, similarly numbered components are analogous to components in the previous figures. Aqueous solution **532** is introduced into the upper region of reactor vessel **500** via atomizer/sprayer unit **504**. Aqueous solution **532** may be introduced directly into the lower region of the reactor vessel

**500** as shown. Gas stream **512a** enters the upper region of reactor vessel **500** where it contacts aqueous solution **532**, which serves to hydrate  $\text{CO}_2$ , forming carbonic acid **544**. Aqueous solution **532** that is unreacted and carbonic acid **544** travel by gravity flow to the lower region of reactor vessel **500** where they impinge and wet carbonate **552** contained therein. The gas stream **512b** enters the lower region of reactor vessel **500** and becomes hydrated as it bubbles through a region of unreacted aqueous solution **532** forming carbonic acid **544**. Alternatively, gas stream **512b** may be bubbled into a region of carbonate solution **552** whereby the  $\text{CO}_2$  hydration and carbonate-carbonic acid reactions occur in solution. The gas stream **512c** enters the lower region of reactor vessel **500** and passes over or through wetted carbonate **552** wherein the  $\text{CO}_2$  hydration and carbonate-carbonic acid reactions occur in close proximity. Prior to exiting from the reactor vessel **500**, the  $\text{CO}_2$ -depleted gas stream **522** may be passed through a moisture-eliminator **508**. The carbonic acid solution **544** reacts with carbonate **552** to form metal ion/bicarbonate solution **546**. Mixture **542** comprises metal ion/bicarbonate solution **546**, unreacted aqueous solution **532**, and unreacted carbonic acid **544**. Mixture **542** is bled from the reactor and disposed of as waste solution **542b** and/or recirculated **542a**. Water **536b** may be added to mixture **542a** as it is circulated back to atomizer/sprayer unit **504**, or water **536a** may be added directly to the lower region of the reactor vessel **500**. Carbonate recharge means **534b** is provided for adding carbonate to mixture **542a** as it is recirculated. Carbonate recharge means **534a** is provided for adding carbonate to the lower region of reactor vessel **500**. Carbonate recharge means **534c** is provided for blowing or spraying fine carbonate particles (dry, wetted or dissolved) into the reactor vessel **500**. Carbonate recharge means **534d** is provided for pouring carbonate into reactor **500**. Carbonate **534e** may be introduced into reactor vessel **500** via a moving structure such as conveyor belt **514**, entering via port **510**. To prevent entrainment of large particulate carbonate, mixture **542** may be passed through a solid/liquid separation means, such as a filter, **506**. A liquid-porous container **556** may be used to hold particulate carbonate **552** which would facilitate replenishment as the carbonate becomes depleted. In the present invention, the reactor vessel **500** may have a tapered bottom section **573** in which solid residue **576** resulting from the carbonic acid/carbonate reaction may collect. The bottom section **573** has a closeable port **575** which allows removal of the solid residue **576**.

#### Sequential $\text{SO}_2$ and $\text{CO}_2$ Removal (Conventional $\text{SO}_2$ Removal)

In the case of sulfur contamination, for example from coal-derived flue gas, it would be advantageous to place this  $\text{CO}_2$  sequestering apparatus downstream from a  $\text{SO}_2$  flue gas scrubber. The gaseous output from said scrubber would have had the sulfur largely removed so that the potential for downstream  $\text{SO}_3^{2-}$  and/or  $\text{SO}_4^{2-}$  formation would be reduced. One such flue gas desulfurization process which reacts limestone with water and  $\text{SO}_2$  ultimately adds additional  $\text{CO}_2$  to the already  $\text{CO}_2$ -rich waste gas stream. This  $\text{CO}_2$  burden could be reduced by the downstream addition of a reactor type described here.

Another embodiment according to the present invention is described hereunder with reference to FIG. 6. This embodiment comprises: an  $\text{SO}_2$ -removal apparatus **602** located upstream of the  $\text{CO}_2$ -removal apparatus **605** described in FIGS. 1-5.  $\text{SO}_2$ -removal apparatus **602** removes  $\text{SO}_2$  from the incoming gas stream **601** by means well known in the art, such as is described in U.S. Pat. No. 5,788,944 which is

incorporated herein by reference. Depleted-SO<sub>2</sub> gas stream **604** exits SO<sub>2</sub>-removal apparatus **602** and enters CO<sub>2</sub> removal apparatus **605**. Depleted-SO<sub>2</sub>/CO<sub>2</sub> gas stream **603** exits CO<sub>2</sub>-removal apparatus **605** as shown. Carbonate recharge **634** may be provided as shown. Water **636** may be added as shown. Metal ions/bicarbonate waste solution **606** exits the apparatus as shown.

#### Integrated SO<sub>2</sub> and CO<sub>2</sub> Removal

SO<sub>2</sub> and CO<sub>2</sub> extraction and sequestration may be integrated into a single reactor with sufficient volume and carbonate surface area to allow both processes to proceed simultaneously. This presumes that certain possible end products or by-products of the sulfur reactions (e.g., SO<sub>3</sub><sup>-</sup> and SO<sub>4</sub><sup>2-</sup>) are indeed deleterious to the carbonate-carbonic acid reaction, and can be removed, chemically bound, or otherwise do not occur in sufficient concentration to unacceptably hinder or impede the carbonate-carbonic acid reactions. If the reacted sulfur exists in such a reactor or its waste stream as SO<sub>3</sub><sup>-</sup> in solution with HCO<sub>3</sub><sup>-</sup>, the former ions could be precipitated and removed as CaSO<sub>4</sub> via aeration of the reactor or waste solution. Integrated SO<sub>2</sub> and CO<sub>2</sub> reactors would be advantageous for new exhaust gas treatment installations, whereas addition of a separate downstream CO<sub>2</sub> reactor would be more cost effective in retrofit situations where a desulfurization reactor is already in place.

Further embodiments according to the present invention are described hereunder with reference to FIG. 7. In these embodiments, SO<sub>2</sub> and CO<sub>2</sub> removal from incoming gas streams **712a, b, c** occur in an integrated reactor **700** of the types described in FIGS. 1-5, but which is of sufficient volume and provides sufficient carbonate surface area to allow reaction and sequestration of both SO<sub>2</sub> and CO<sub>2</sub>. Unless otherwise stated, similarly numbered components are analogous to components in the previous figures. When sulfur dioxide is hydrated, sulfurous acid is formed. The sulfurous acid reacts with carbonate to form metal ions and sulfite in solution, along with additional carbon dioxide. These embodiments described herein provide for sequestering this additional CO<sub>2</sub> as well as that present in the original gas stream. This additional CO<sub>2</sub> would be hydrated by aqueous solution present in the reactor. Although FIG. 7 shows just one integrated reactor, a cascading series of integrated reactors may be advantageous wherein the first reactors in the series remove the bulk of the SO<sub>2</sub>, and the later reactors remove CO<sub>2</sub>.

Incoming gas stream **712a** enters reactor **700** and is hydrated by aqueous solution **732** which has been introduced into the upper region of reactor vessel **700** in the form of mist or droplets via atomizer/sprayer unit **704**. Aqueous solution **732** comprises water and may include one or more of the following: dissolved carbon dioxide, carbonic acid, sulfurous acid, metal ions, bicarbonate, particulate carbonate and dissolved carbonate. Contact between the gas stream **712a** and aqueous solution **732** serves to hydrate the SO<sub>2</sub> and CO<sub>2</sub>, forming respectively, sulfurous acid **745** and carbonic acid **744**. Aqueous solution **732** may also be introduced directly into the lower region of reactor vessel **700**. Aqueous solution **732** that is unreacted, sulfurous acid **745** and carbonic acid **744**, contact carbonate **752** contained in reactor vessel **700**. The gas stream **712b** enters the lower region of reactor vessel **700** and becomes hydrated as it bubbles through a region of unreacted aqueous solution **732** forming sulfurous acid **745** and carbonic acid **744**. Alternatively, the gas stream **712b** may be bubbled into a region of carbonate solution **752**, whereby acid formation and acid/carbonate reactions occur in solution. The gas stream **712c** enters the lower region of reactor vessel **700** and passes over or through wetted carbonate **752**

wherein the SO<sub>2</sub> and CO<sub>2</sub> hydration, and acid/carbonate reactions occur in close proximity. The SO<sub>2</sub>/CO<sub>2</sub>-depleted gas stream **722** exits the reactor vessel **700**. Prior to exiting from the reactor vessel **700**, the gas stream **722** may be passed through a moisture eliminator **708**. Monitoring means **729** is provided for monitoring the CO<sub>2</sub> concentration in gas stream **722**. The gas stream **722** may be recirculated **724** back into reactor vessel **700** should further CO<sub>2</sub> removal be necessary. The carbonic acid **744** reacts with carbonate **752** to form metal ions/bicarbonate solution **746**. The sulfurous acid **745** reacts with carbonate **752** to form metal ions/sulfite solution **747** and additional CO<sub>2</sub>. This additional CO<sub>2</sub> will also be hydrated to form additional carbonic acid **744** as it contacts aqueous solution **732**. Mixture **781**, comprising aqueous solution **732**; sulfurous acid **745**; metal ions/sulfite solution **747**; carbonic acid **744**; and metal ions/bicarbonate solution **746**, is bled from the reactor, and may be passed through an aeration unit **782** which precipitates metal sulfate **784a**. During such aeration, to prevent CO<sub>2</sub> removal and hence carbonate precipitation from the waste solution it would be advantageous to elevate the pCO<sub>2</sub> of the aerating gas. Aerated waste stream **784b** may be disposed of as waste solution **784c**, recirculated **784d** back to the spray unit **704**, and/or recirculated directly **784e** back to the lower region of reactor vessel **700** should sampling indicate that further reaction of the waste solution with the carbonate **752** is warranted. Additional water **736b** may be added to recirculated waste solution **784d** or may be added directly **736a** to the lower region of reactor vessel **700** as shown. Means **734** is provided for adding carbonate to reactor vessel **700**. To prevent entrainment of large particulate carbonate in mixture **781**, a solids/liquids separator **706** may be located at the exit port of the reactor vessel **700**. Mixture **781** may contain waste products including SO<sub>3</sub><sup>-</sup>, HCO<sub>3</sub><sup>-</sup>, and metal ions in solution, plus any mineral sulfate precipitated in the reactor or in the waste solution stream. Monitoring means **749** and **799** are provided for measuring one or more solution chemistry parameters such as pH, pCO<sub>2</sub>, conductivity, alkalinity, and/or metal ion concentration in mixture **781** (either within the reactor vessel or as the mixture is transported outside of the reactor vessel) and/or in other downstream solutions such as **784b**).

#### Sequential SO<sub>2</sub> and CO<sub>2</sub> Removal

Further embodiments according to the present invention are described hereunder with reference to FIG. 8. In these embodiments, SO<sub>2</sub> and CO<sub>2</sub> removal from gas streams **812a** and **b** occur in a sequential configuration of the types described in FIGS. 2-5, where the hydration vessel and carbonate reaction vessel are of sufficient volume and provide sufficient carbonate surface area to allow reaction and sequestration of both SO<sub>2</sub> and CO<sub>2</sub>. Unless otherwise stated, similarly numbered components are analogous to components in the previous figures. When sulfur dioxide is hydrated, sulfurous acid is formed. The sulfurous acid reacts with carbonate to form metal ions and sulfite in solution, along with additional carbon dioxide. This present invention provides for sequestering this additional CO<sub>2</sub> as well as that present in the original gas stream. Incoming gas stream **812a** enters reactor **800** and is hydrated by aqueous solution **832** which has been introduced into the upper region of hydration vessel **800** in the form of mist or droplets via atomizer/sprayer unit **804**. Aqueous solution **832** comprises water and may include one or more of the following: dissolved carbon dioxide, sulfur dioxide, carbonic acid, sulfurous acid, metal ions, bicarbonate, bisulfite, particulate carbonate, dissolved carbonate, particulate sulfate, and dissolved sulfate. Contact between the gas stream **812a** and aqueous solution **832** serves to hydrate the

SO<sub>2</sub> and CO<sub>2</sub>, forming respectively, sulfurous acid **845** and carbonic acid **844**. Alternatively or in addition to gas stream **812a**, gas stream **812b** enters the lower region of hydration vessel **800** and becomes hydrated as it bubbles through a region of pooled liquid comprising unreacted aqueous solution **832**, sulfurous acid **845** and carbonic acid **844**. Gas stream **812b** may be passed through gas diffuser **867** to enhance dispersal of the gas into said pooled liquid. Aqueous solution **832** may also be introduced directly into the lower region of hydration vessel **800**. The SO<sub>2</sub>/CO<sub>2</sub>-depleted gas stream **822** exits the hydration vessel **800**. Prior to exiting from the hydration vessel **800**, the gas stream **822** may be passed through a moisture eliminator **808**. Monitoring means **829** is provided for monitoring the SO<sub>2</sub> and CO<sub>2</sub> concentrations in gas stream **822**. The gas stream **822** may be recirculated **824** back into hydration vessel **800** should further SO<sub>2</sub> and/or CO<sub>2</sub> removal be necessary. Mixture **842** comprises sulfurous acid **845**, carbonic acid **844**, aqueous solution **832** and may contain mixture **884d**. Mixture **842** is transported to carbonate reaction vessel **850** as shown **842b**, or recirculated **842a**. Water **836b** may be added to aqueous solution **832**, or water **836a** may be added directly to the lower region of the hydration vessel **800**. Mixture **842b** may be introduced into the upper region of carbonate reaction vessel **850** in the form of mist or droplets **842c** via atomizer/sprayer unit **854**, and/or directly **842d** into the lower region of carbonate reaction vessel **850**. Mixture **842c** and/or **842d** react with carbonate **852** contained in the lower region of carbonate reactor **850** to form metal ions/bicarbonate/sulfite solution **894**. Any CO<sub>2</sub> resulting from the reaction of sulfurous acid contained in mixtures **842c** and **842d** with carbonate **852** will be hydrated by the same said mixtures to form carbonic acid. Mixture **892** comprises metal ion/bicarbonate/sulfite solution **894** and unreacted mixtures **842c** and **842d** which have pooled in the lower region of carbonate reaction vessel **850**. Means **834** for adding carbonate to reactor vessel **850** is provided. Mixture **892** is bled from the carbonate reaction vessel, and may be passed through a solid/liquid separation means, such as a filter **856**, in order to prevent entrainment of particulates. Mixture **892** may also be passed through an aeration unit **882** which precipitates metal sulfate **884a**. During such aeration, to prevent net CO<sub>2</sub> removal and hence carbonate precipitation from the waste solution it would be advantageous to elevate the pCO<sub>2</sub> of the aerating gas so that it equals the pCO<sub>2</sub> of solution **892**. Aerated waste stream **884b** may be disposed of as waste solution **884c**, recirculated **884d** back to hydration vessel **800** for facilitating further SO<sub>2</sub> and CO<sub>2</sub> hydration, added **884f** to recirculated mixtures **842a,b**, and/or recirculated directly **884e** back to the lower region of reactor vessel **800** should sampling indicate that further reaction of the waste solution with the carbonate **852** is warranted. Mixture **892** may contain waste products including HSO<sub>3</sub><sup>-</sup>, SO<sub>3</sub><sup>2-</sup>, HCO<sub>3</sub><sup>-</sup>, and metal ions in solution, plus any mineral sulfate and carbonate precipitated in the reactor or contained in the waste solution stream. Monitoring means **849** and **899** are provided for measuring one or more solution chemistry parameters such as pH, pCO, conductivity, alkalinity, and/or metal ion concentration in mixtures **842** and **892** and/or in downstream solutions such as **842b** and **884d**. Carbonate reaction vessel **850** may also contain gas/heat exchange means **872** whereby gas is vented and heat may be exchanged with the ambient atmosphere to moderate interior gas pressure and temperature.

#### Waste Stream Solution Chemistry Modification

To minimize degassing and loss of CO<sub>2</sub> from the waste stream solution to the atmosphere as well as to minimize

carbonate precipitation, various means may be used, including pre-treatment of the waste stream solution before release, and consideration of the disposal site into which the waste stream solution will be released.

Pre-treatment of the waste stream solution may include CO<sub>2</sub> degassing, dilution with an undersaturated solution, chemical additives, ion exchange, and modification of density, temperature or solute concentrations. CO<sub>2</sub> degassing may be passive wherein the waste stream solution is allowed to degas to an overlying headspace whose pCO<sub>2</sub> is less than that of the waste stream solution. Active degassing may be accomplished by purging with a gas stream (such as air) whose pCO<sub>2</sub> is less than that of the waste stream solution. Degassing could also be induced by applying a (partial) vacuum to the headspace above the waste stream solution. The degassed CO<sub>2</sub> may be recycled back to the input gas stream of the CO<sub>2</sub> hydration/carbonate reactor for further capture and sequestration. The waste stream solution may be diluted with a solution which is undersaturated with respect to CO<sub>2</sub> and/or carbonate ions. Such dilution would include dilution with water (freshwater or seawater) before release into the disposal site, or the natural mixing and dilution that would occur after the waste stream solution were released into a large body of water (freshwater or seawater, size on the order of a river, lake, sea or ocean). Certain chemicals, including phosphate, metals, and EDTA and other organic compounds (including: humic substances, aromatic acids, citrate, malate, pyruvate, glycelglycerine, glycogen, arginine, glutamate, glycine, glycoprotein succinate, taurine, chondroitin sulfate, galactose, dextrose and acetate) may be added to the waste stream solution to impede carbonate precipitation.

To reduce the potential for carbonate precipitation, at least some of the Ca<sup>2+</sup> cations in the waste stream solution may be replaced with cations which when balanced by the CO<sub>3</sub><sup>2-</sup> anions exhibit great solubility and less propensity for precipitation than does CaCO<sub>3</sub>. One means of achieving this is by passing the waste stream solution through an ion exchange resin containing weakly attached exchangeable ions. Ca<sup>2+</sup> ions can be at least partially removed from water (water softening) by passing the water through a cation exchange column where the exchangeable ions on the resin are Na<sup>+</sup> such that 2Na<sup>+</sup> replaces at least some of the Ca<sup>2+</sup> in solution and the Ca<sup>2+</sup> is bound to the resin. Thus at least some of the original CaCO<sub>3</sub> dissolved in the original solution is thus converted to the more soluble Na<sub>2</sub>CO<sub>3</sub>. Ca can be removed from the resin and the resin recharged with Na by passing a concentrated NaCl solution through the resin forming a waste solution of CaCl<sub>2</sub> and residual NaCl which can be used for other purposes or discarded. Use of replacement cations other than Na<sup>+</sup> can be considered as long as the solubility of the dissolved carbonate so obtained is greater than that of CaCO<sub>3</sub>.

At least some of the CO<sub>3</sub><sup>2-</sup> anions may be removed from the waste stream solution by passage through an anion exchange column wherein CO<sub>3</sub><sup>2-</sup> is replaced by another anion (e.g. 2Cl<sup>-</sup>). The CO<sub>3</sub><sup>2-</sup> is retained by the resin, producing CaCl<sub>2</sub> in the solution. The resin could ultimately be regenerated via passage of a solution of concentrated NaCl through the resin forming a solution of Na<sub>2</sub>CO<sub>3</sub> and residual NaCl, which could be use for other purposes or discarded.

Through similar ion exchange processes to those above, at least some of the Ca(HCO<sub>3</sub>)<sub>2</sub> dissolved in the waste stream solution may be converted to non-Ca moieties, or the HCO<sub>3</sub><sup>-</sup> concentration reduced, with the eluates from the resin regeneration step used for other purposes or discarded.

The density of the waste stream solution may be adjusted, preferably increased, to facilitate sinking and mixing of the waste stream solution with the disposal site solution. The

density may be adjusted upward via a decrease in the waste stream solution temperature and/or an increase in solute concentrations.

Selection of the disposal site should consider various factors. The preferred disposal site is a large body of water, such as a river, lake, sea or ocean. It is preferred that the  $p\text{CO}_2$  and/or carbonate ion concentration of the disposal site solution at the point of release of the waste stream solution into the disposal site be lower than that of the waste stream solution. The depth at which the waste stream solution is released into the disposal site solution is also a consideration so as to minimize contact with the atmosphere and hence  $\text{CO}_2$  degassing and carbonate precipitation. In this regard it is preferred that the depth of release be below the pycnocline. Although release below the pycnocline is preferred, disposal of the waste solution at or near the ocean surface may also be acceptable if: i) mixing and dilution with surface seawater is sufficiently rapid and/or ii) the concentration of certain ions or compounds naturally in seawater are sufficient to at least partially impede carbonate precipitation. Also, because of the high  $\text{CO}_3^{2-}$  concentration of the waste effluent, it may be advantageous to release this effluent in the vicinity of coral reefs, so as to prevent environmental degradation of the reefs that have or will result from reductions in ambient  $\text{CO}_3^{2-}$  concentrations via anthropogenic increases in atmospheric and, by equilibration, surface ocean  $\text{CO}_2$  concentrations.

Although surface seawater is supersaturated with respect to calcite, precipitation is kinetically impeded by the presence of certain naturally occurring ions and organic compounds in the seawater which can complex or associate with  $\text{Ca}^{2+}$ . Such ions or compounds thus far shown to affect carbonate precipitation include:  $\text{Mg}^{2+}$ , phosphate, and various organic compounds including: humic substances, aromatic acids, citrate, malate, pyruvate, glycerolglycerine, glycogen, arginine, glutamate, glycine, glycoprotein succinate, taurine, chondroitin sulfate, galactose, dextrose and acetate.

It is more preferred that the geographic location and depth of the waste stream solution release be selected so that natural water currents within the disposal site solution facilitate the mixing and dilution of the waste stream solution and reduce its contact with the atmosphere. Increasing depths of release also brings increasing pressure and decreasing temperature both of which impede carbonate precipitation. It is also preferred that the release depth be below the CCD.

A further embodiment is where the reactor vessels (integrated or separate hydration and/or carbonate) are located on a ship, barge, train, truck, automobile or any other means of conveyance. Locating the reactor vessels on or near a large body of water (e.g., river, lake, sea or ocean) would be advantageous because it could allow the relatively inexpensive over-water transport of carbonate, provide a ready source of water for the reactor, and provide a place to dispose of the reactor's relatively benign-liquid waste stream.

A further embodiment is where the gas stream containing  $\text{CO}_2$  comprises exhaust gas from various modes of transportation, allowing one to sequester  $\text{CO}_2$  from these mobile sources, such modes including but not limited to seacraft, aircraft, and land based vehicles such as trains, trucks, buses, and automobiles.

Obviously numerous modifications and variations of the present invention are possible in the light of the above teachings. It is therefore to be understood that within the scope of the appended claims the invention may be practiced otherwise than as specifically described therein.

What is claimed is:

1. An apparatus for extracting and sequestering  $\text{CO}_2$  from a gas stream, comprising:

a reactor vessel;  
 an aqueous solution;  
 means for introducing said gas stream into said reactor vessel;  
 carbonate disposed in said reactor vessel, wherein said carbonate is of the form  $\text{X}(\text{CO}_3)_m$  wherein X is any element or combination of elements that can chemically bond with a carbonate group or its multiple, wherein at least one said element is a group IA, IIA, IIIA, IVA, IB, IIB, IIIB, IVB, VB, VIIB, VIIIB, or VIIIIB element of the periodic table, and  
 wherein m is a stoichiometrically determined positive integer;  
 means for hydrating said  $\text{CO}_2$  with said aqueous solution to form carbonic acid, thereby resulting in a  $\text{CO}_2$ -depleted gas stream;  
 means for removing said  $\text{CO}_2$ -depleted gas stream from said reactor vessel;  
 means for reacting said carbonate with said carbonic acid to form a waste stream solution of metal ions and bicarbonate;  
 means for removing said waste stream solution from said reactor vessel;  
 an ion exchange device for pre-treating said waste stream solution to reduce the amount of  $\text{CO}_2$  outgassing and carbonate precipitation that may occur after said waste stream solution is released into a disposal site; and  
 means for releasing said pretreated waste stream solution into said disposal site.

2. The apparatus as recited in claim 1 wherein: said disposal site comprises a body of water that is either freshwater or seawater.

3. The apparatus as recited in claim 2 wherein: the  $p\text{CO}_2$  of said body of water at the point of release of waste stream solution is less than that of said waste stream solution.

4. The apparatus as recited in claim 2 wherein: said releasing means comprises means for releasing said waste stream solution at a depth sufficient for mixing and dilution of said waste stream solution with said body of water to occur.

5. The apparatus as recited in claim 2 wherein: said releasing means comprises means for releasing said waste stream solution at a depth wherein the pressure and temperature existent at said depth is sufficient to impede  $\text{CO}_2$  outgassing to the atmosphere and carbonate precipitation.

6. The apparatus as recited in claim 2 wherein: said body of water is either a sea or ocean; and said releasing means causes said waste stream solution to be released below the pycnocline.

7. The apparatus as recited in claim 2 wherein: said body of water is either a sea or ocean; and said releasing means causes said waste stream solution to be released in the vicinity of a reef, above the pycnocline.

8. The apparatus as recited in claim 2 wherein: said disposal site is a body of surface seawater having sufficient constituents that serve to impede carbonate precipitation, said constituents being phosphate,  $\text{Mg}^{2+}$  ions, or phosphate and  $\text{Mg}^{2+}$  ions.

9. The apparatus as recited in claim 2 wherein: said disposal site is a body of surface seawater having sufficient organic compounds that serve to at least partially impede carbonate precipitation, said organic compounds selected from the group consisting of humic substances, aromatic acids, citrate, malate, pyruvate,

## 23

glycelglycerine, glycogen, arginine, glutamate, glycine, glycoprotein succinate, taurine, chondroitin sulfate, galactose, dextrose and acetate.

10. The apparatus as recited in claim 2 wherein:

said body of water is either a sea or ocean;

and said pretreated waste stream solution is released at a depth below the carbonate compensation depth (CCD).

11. An apparatus for extracting and sequestering CO<sub>2</sub> from a gas stream, comprising:

a reactor vessel;

an aqueous solution;

means for introducing said gas stream into said reactor vessel;

carbonate disposed in said reactor vessel, wherein said carbonate is of the form X(CO<sub>3</sub>)<sub>m</sub>, wherein X is any element or combination of elements that can chemically bond with a carbonate group or its multiple, wherein at least one said element is a group IA, IIA, IIIA, IVA, IB, IIB, IIIB, IVB, VB, VIIB, VIIIB, or VIIIIB element of the periodic table, and

wherein m is a stoichiometrically determined positive integer;

means for hydrating said CO<sub>2</sub> with said aqueous solution to form carbonic acid, thereby resulting in a CO<sub>2</sub>-depleted gas stream;

means for removing said CO<sub>2</sub>-depleted gas stream from said reactor vessel;

means for reacting said carbonate with said carbonic acid to form a waste stream solution of metal ions and bicarbonate;

means for removing said waste stream solution from said reactor vessel;

an ion exchange device for pre-treating said waste stream solution by exchanging at least a portion of the Ca<sup>2+</sup> cations present in said waste solution with exchange cations which when balanced by the CO<sub>3</sub><sup>2-</sup> anions present in said waste solution exhibit greater solubility and less propensity for precipitation than does CaCO<sub>3</sub>; and

## 24

means for releasing said pretreated waste stream solution into a disposal site.

12. The apparatus as recited in claim 11 wherein:

said ion exchange device comprises means for passing said waste stream solution through an ion exchange column, with said column containing Na<sup>+</sup> exchange ions.

13. An apparatus for extracting and sequestering CO<sub>2</sub> from a gas stream, comprising:

a reactor vessel;

an aqueous solution;

means for introducing said gas stream into said reactor vessel;

carbonate disposed in said reactor vessel, wherein said carbonate is of the form X(CO<sub>3</sub>)<sub>m</sub>, wherein X is any element or combination of elements that can chemically bond with a carbonate group or its multiple, wherein at least one said element is a group IA, IIA, IIIA, IVA, IB, IIB, IIIB, IVB, VB, VIB, VIIB, or VIIIIB element of the periodic table, and

wherein m is a stoichiometrically determined positive integer;

means for hydrating said CO<sub>2</sub> with said aqueous solution to form carbonic acid, thereby resulting in a CO<sub>2</sub>-depleted gas stream;

means for removing said CO<sub>2</sub>-depleted gas stream from said reactor vessel;

means for reacting said carbonate with said carbonic acid to form a waste stream solution of metal ions and bicarbonate;

means for removing said waste stream solution from said reactor vessel;

an ion exchange device for pre-treating said waste stream solution by exchanging at least a portion of the CO<sub>3</sub><sup>2-</sup> anions present in said waste solution with other anions; and

means for releasing said pretreated waste stream solution into a disposal site.

\* \* \* \* \*